

SCALE 1 : 10

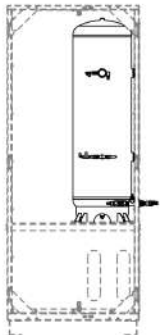

SCALE 1 : 32

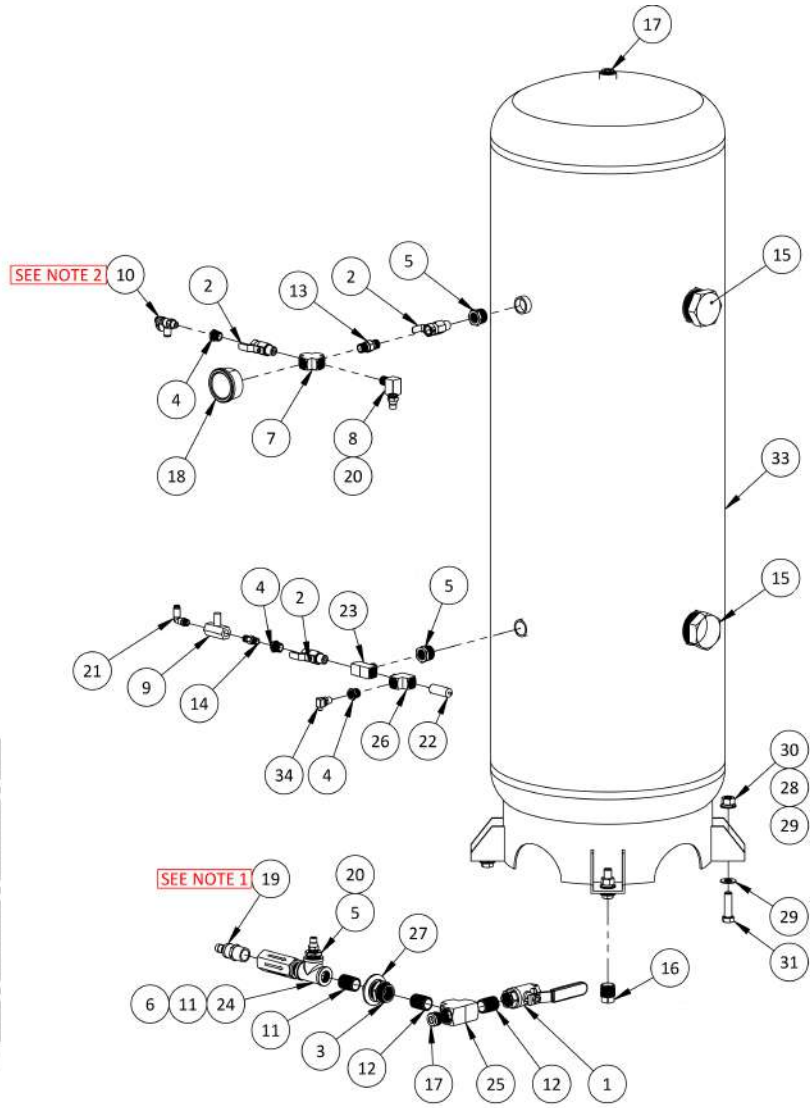

ITEM #	NUMBER	DESCRIPTION	QTY.
1	100776	0.500" NPT F BALL VALVE, BRASS	1
2	100785	0.250 NPT M X F MINI BALL VALVE, BRASS, 500PSI	3
3	100897	0.500 NPT F BULKHEAD, BRASS	1
4	100916	0.250 NPT X 0.125 NPT BUSHING, BRASS	3
5	100997	0.500" NPT X 0.250" NPT BUSHING, GLV	3
6	101065	0.500 NPT F CHECK VALVE, BRASS	1
7	101204	0.250 NPT F CROSS, BRASS	1
8	101271	0.250 NPT STREET ELBOW, BRASS	1
9	101461	0.125 NPT EASY READ NEEDLE VALVE, BRASS	1
10	101470	0.125 NPT X 0.250 OD PTC ELBOW FLOW CONTROLLER	1
11	101759	0.500 NPT CLOSE NIPPLE, GALVANIZED	2
12	101676	0.500 NPT CLOSE NIPPLE, BRASS	2
13	101687	0.250 NPT HEX NIPPLE, BRASS	1
14	101688	0.125 NPT HEX NIPPLE, BRASS	1
15	101882	0.1.500" NPT SQUARE HEAD PLUG, GLV	2
16	101894	0.500" NPT SQUARE HEAD PLUG, GLV	1
17	101931	0.500 HEX DRIVE PLUG, BRASS	2
18	101943	0.250 NPT X 02.000 RMPG, 0-160 PSI	1
19	101995	0.500 NPT X 0.500 PUSH-ON BARB SWIVEL, PS	1
20	102066	0.250 NPT X 0.250 OD PTC STRAIGHT	2
21	102075	0.125 NPT X 0.250 OD PTC SWIVEL ELBOW	1
22	102175	0.250 NPT SAFETY RELIEF VALVE, 135 PSI, 119 SCFM	1
23	102283	0.250 NPT F X 0.250 NPT M X 0.250 NPT F BRANCH TEE, BRASS	1
24	103930	0.500" NPT F TEE, GLV	1
25	102305	0.500 NPT F TEE, BRASS	1
26	102313	0.250 NPT STREET TEE, BRASS	1
27	102597	01.125" ID X 01.750" OD WASHER FOR BULKHEADS	1
28	102606	0.4375 YELLOW ZINC FINISH MEDIUM SPLIT LOCK WASHER	4
29	102607	0.4375" YELLOW ZINC FINISH SAE FLAT WASHER	8
30	102688	0.4375"-14 YELLOW ZINC FINISH GRADE 8 HEX NUT	4
31	102842	0.4375-14 X 01.500 HHCS. GR8, YZ	4
32	103002	0.500" ID BLACK PUSH-ON HOSE, PER INCH	24
33	105060	00028 GALLON, 135 PSI ASME STORAGE TANK	1
34	111219	0.125 NPT PRESS SNSR, 1-5 ANLG OUT	1

ITEM #	NUMBER	DESCRIPTION	QTY.
1	102049	0.375 NPT X 0.500 OD PTC SWIVEL ELBOW	2
2	102051	0.375 NPT X 0.375 OD PTC ELBOW	2
3	102320	0.375 NPT STREET TEE, BRASS	2
4	102607	0.4375" YELLOW ZINC FINISH SAE FLAT WASHER	16
5	102842	0.4375-14 X 0.500 HHCS, GR 8, YZ	8
6	106442	0.750 NPT X 0.375 NPT BUSHING, BLACK	2
7	102606	0.4375 YELLOW ZINC FINISH MEDIUM SPLIT LOCK WASHER	8
8	102688	0.4375"-14 YELLOW ZINC FINISH GRADE 8 HEX NUT	8
9	104281	8" OD X 36" STS SIEVE BED	2

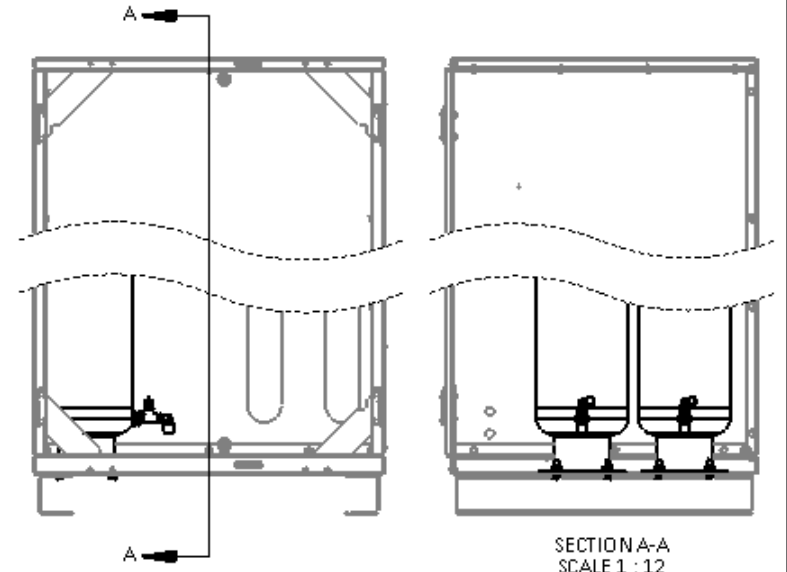
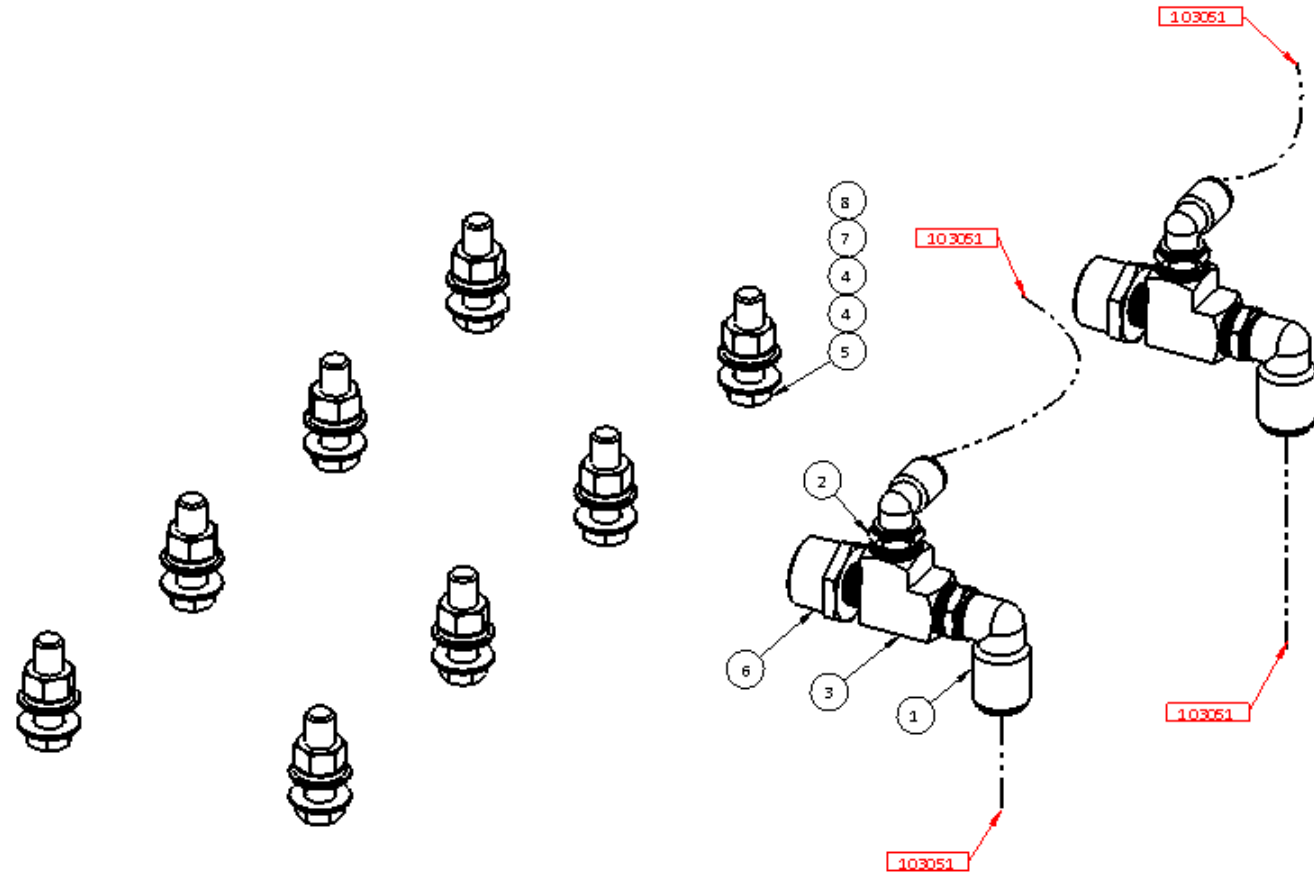

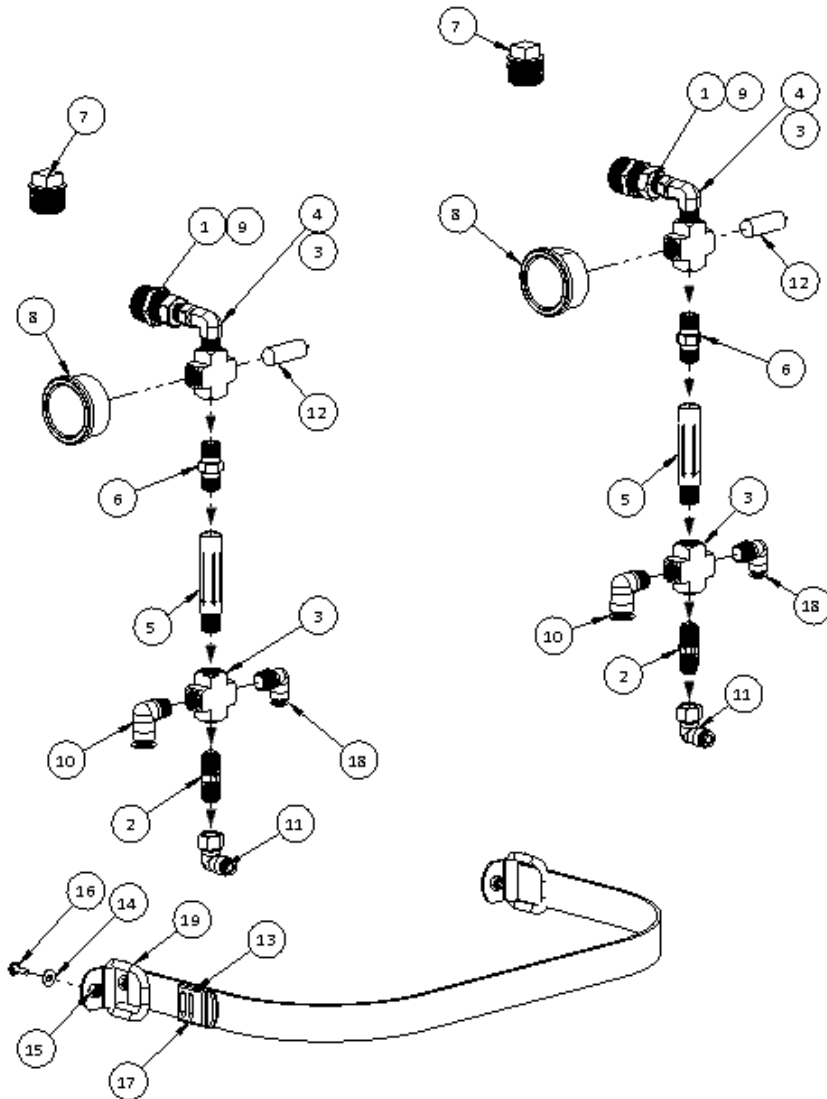

DRILL CLEARANCE HOLE FOR
#10 HARDWARE.
DIMENSIONS PROVIDED ARE
FOR NEW REV CABINETS

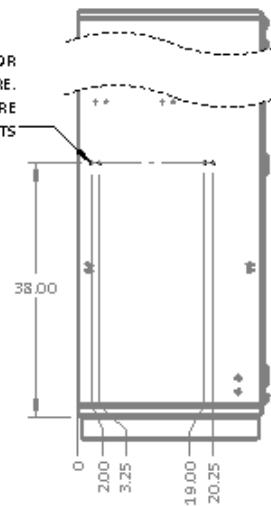

ITEM #	NUMBER	DESCRIPTION	QTY.
1	100986	0.750" NPT X 0.500" NPT BUSHING, G LV	2
2	101068	0.250 NPT X 0.250 NPT CHECK VALVE, BRASS	2
3	101204	0.250 NPT F CROSS, BRASS	4
4	101331	0.250" NPT X 0.250" NPT F SWIVEL NUT ELBOW	2
5	101509	0.250 NPT INLINE FILTER, 40 MICRON, ALUMINUM	2
6	101687	0.250 NPT HEX NIPPLE, BRASS	2
7	101932	0.750" NPT SQUARE HEAD PLUG, G LV	2
8	101943	0.250 NPT X 0.2000 RMPG, 0-160 PSI	2
9	102015	0.500 NPT X 0.250 NPT HEX NIPPLE, BRASS	2
10	102064	0.250 NPT X 0.375 OD PTC ELBOW	2
11	102072	0.250 NPT F X 0.250 OD PTC SWIVEL ELBOW	2
12	102142	0.250 NPT SAFETY RELIEF VALVE, 150 PSI, 130SCFM	2
13	102442	LIGHT DUTY PLASTIC BUCKLE	1
14	102608	#10 SAE FLAT WASHER, ZINC	4
15	102692	10-32 Nylock Nut	4
16	102799	10-32 X 0.500" PPHMS, ZINC	4
17	103023	NYLON WEBSTRAP	72
18	105917	0.250 NPT X 0.250 OD PTC SWIVEL ELBOW	2
19	108206	D-RING ASSEMBLY	2

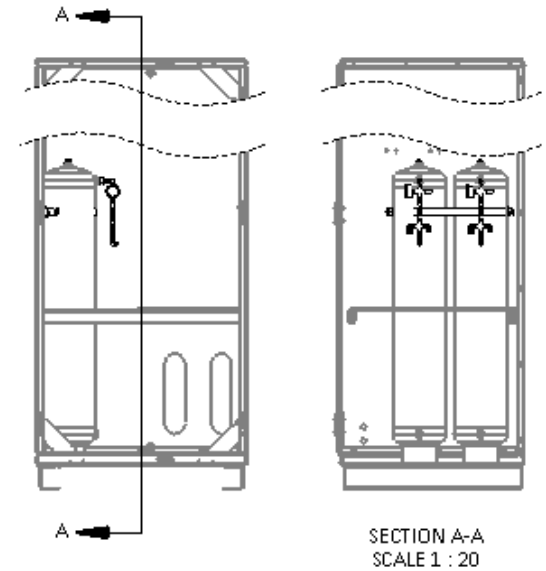

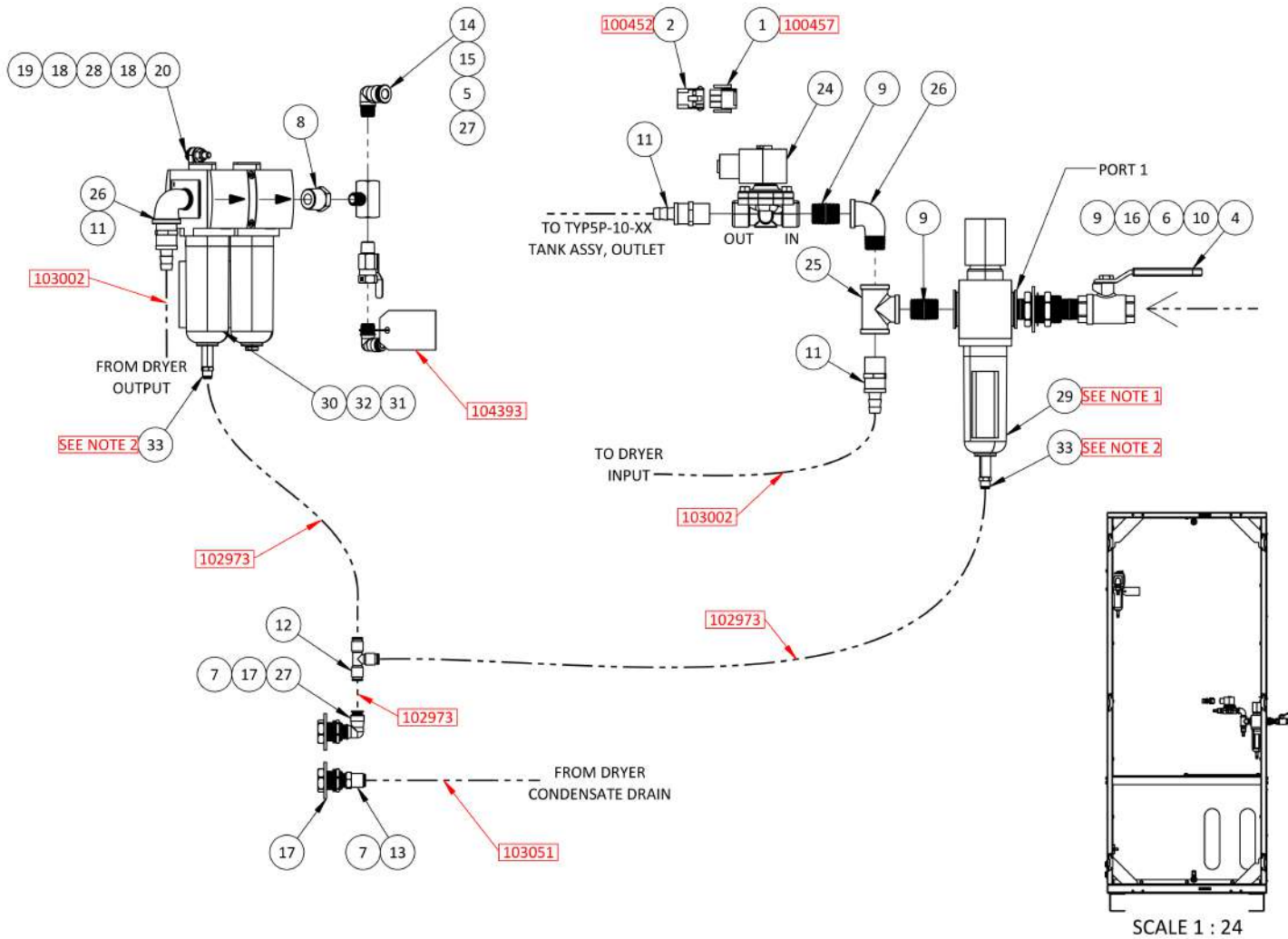

ITEM #	NUMBER	DESCRIPTION	QTY.
1	100450	3 PIN PLUG	1
2	100452	3 PIN CAP	1
3	100457	MALE UNIVERSAL PIN, 20-14 AWG, PRE-TINNED BRASS	3
4	100776	0.500" NPT F BALL VALVE, BRASS	1
5	100785	0.250 NPT M X F MINI BALL VALVE, BRASS, 500PSI	1
6	100897	0.500 NPT F BULKHEAD, BRASS	1
7	100899	0.250 NPT F BULKHEAD, BRASS	2
8	100999	0.500 NPT X 0.250 NPT BUSHING, BRASS	1
9	101759	0.500 NPT CLOSE NIPPLE, GALVANIZED	3
10	101850	0.500" NPT X 01.500" L NIPPLE, GALVANIZED	1
11	101995	0.500 NPT X 0.500 PUSH-ON BARB SWIVEL, PS	3
12	102053	0.250 OD PTC TEE, LEGRIS	1
13	102063	0.250 NPT X 0.375 OD PTC STRAIGHT	1
14	102064	0.250 NPT X 0.375 OD PTC ELBOW	1
15	102283	0.250 NPT F X 0.250 NPT M X 0.250 NPT F BRANCH TEE, BRASS	1
16	102597	01.125" ID X 01.750" OD WASHER FOR BULKHEADS	1
17	102600	0.750" ID X 1.250" OD WASHER FOR BULKHEADS	2
18	102611	0.250 ZINC FINISH SAE FLAT WASHER	4
19	102690	0.250 - 20 NYLOCK NUT, ZPS	2
20	102845	0.250-20 X 01.000 HEX BOLT, GR8	2
21	102973	0.250" OD NATURAL POLYETHYLENE TUBING, PER IN	96
22	103002	0.500" ID BLACK PUSH-ON HOSE, PER INCH	96
23	103051	0.375 OD NATURAL POLYETHYLENE, PER IN	40
24	103274	0.500 NPT 2 WAY SOLENOID VALVE, 24VC	1
25	103930	0.500" NPT F TEE, GLV	1
26	103931	ST ELB, 0.500" NPT GLV	2
27	105917	0.250 NPT X 0.250 OD PTC SWIVEL ELBOW	2
28	300058	WALL BRACKET, 652 ASCO	1
29	300060	PTCLT FLTR/REG, 0.500 NPT, 5 MICRON	1
30	300062	COALESCING FLTR, 0.500, .01 MICRON	1
31	300063	ADSORBING FILTER, 0.500 NPT	1
32	300064	BODY CLAMP 652 ASCO	1
33	999279	0.125 RC M X 0.250 OD PTC STRAIGHT	2

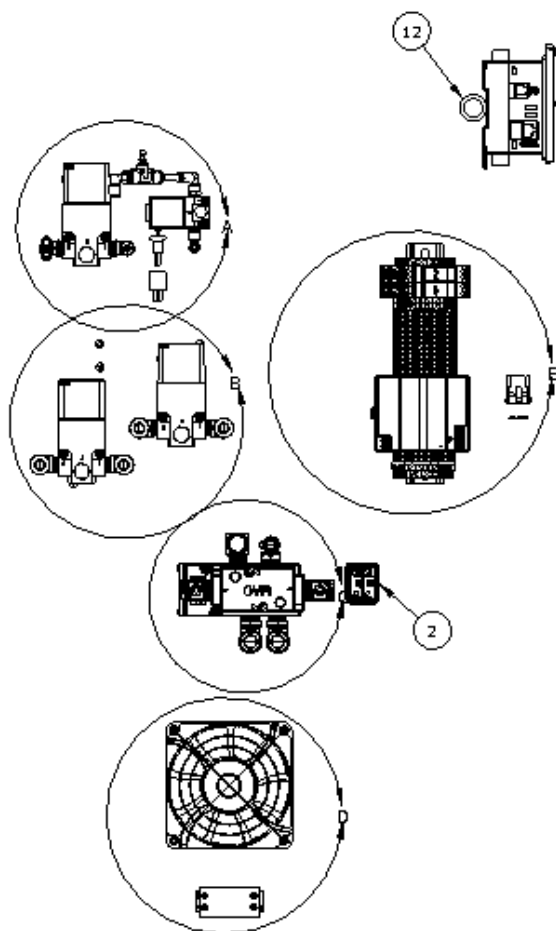

INSTALL IN FRONT RIGHT DOOR PANEL

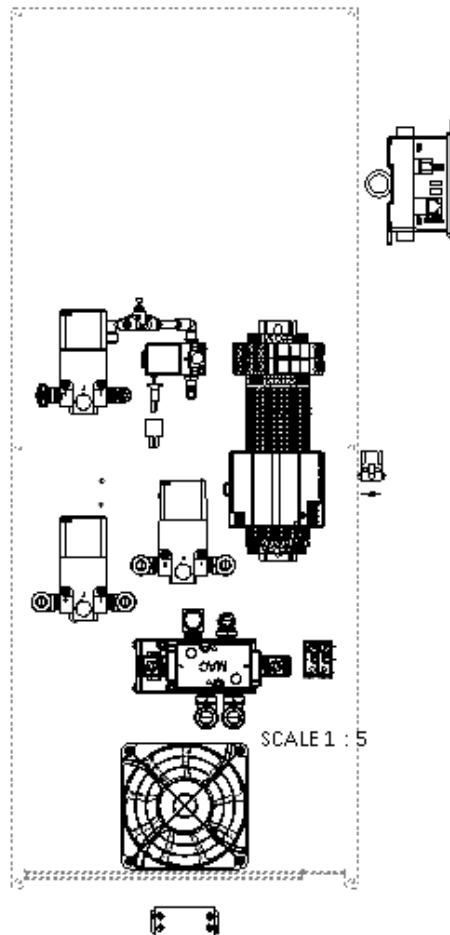

ITEM #	QUANTITY	DESCRIPTION	QTY.
1	100041	COOLING FAN, 100 C/M, 24VDC	1
2	100143	CIRCUIT BREAKER, 15A, DPDT, W/COILAR	1
3	100224	PROG RAM MODULE LOGIC CONTROLLER	1
4	100257	WAGO STRIP, 24 VDC	2
5	100275	SD CARD	1
6	100279	4 POS 14 PIN TERMINAL BLOCK	1
7	100281	DIN MOUNT TERMINAL BLOCK END COVER	2
8	100280	14 PIN TERMINAL BLOCK COVER	1
9	100282	14 PIN TERMINAL BLOCK, 4 POS 28-12AWG	14
10	100297	GROUND BLOCK, DIN RAIL MOUNT	5
11	100401	SNAP ON TERMINAL BLOCK END BRACKET, POLYIMIDE	2
12	100446	TERMINAL COVER, 4 PIN 18 AWG POWER WIRING	1
13	100432	5 PIN CAP	1
14	100435	2 PIN CAP, 4 PIN TERMINAL BLOCK	1
15	100436	2 PIN FLUG, 4 PIN TERMINAL BLOCK	1
16	100437	MALF 4 PIN TERMINAL FLUG, 20-14 AWG, PRE-INSUL BRASS	2
17	100438	14 PIN MALF 4 PIN TERMINAL BLOCK	3
18	100464	140004 BRKT, 1A, 400V	1
19	101297	0.575 NFI 31 FFI FLOW, BRASS	1
20	101464	0.230 OD PIC LOW CONDUCT	1
21	101328	0.575 NFI COM FPCI HIGH TOW MULTIFL STEEL	1
22	101905	0.230 HFF FLUG, BRASS	5
23	101903	0.125 NFI HFF FLUG, BRASS	1
24	102049	0.575 NFI F 0.230 OD PFC SWRFL FLOW	2
25	102031	0.575 NFI F 0.575 OD PFC FLOW	1
26	102034	0.230 OD SIFM WYF	1
27	102033	0.230 SIFM F 0.230 OD PFC FLOW	1
28	102064	0.230 NFI F 0.575 OD PFC FLOW	4
29	102073	0.125 NFI F 0.230 OD PFC SWRFL FLOW	2
30	102092	0.230 SIFM 4404, METAL	1
31	102378	0.125" FUSION METAL FLUG	8
32	102609	AB LAL WASHFR, ZINC FINISH	2
33	102682	8-52 WCC NUT	2
34	102683	8-52 NYLOC NUT	14
35	102691	4-40 HFF NUT	2
36	102791	8-52 F 01230 PPHMS	4
37	102792	4-40 F 0300 PPHMS	2
38	102794	8-52 F 01237 PPHMS	10
39	102237	0.125" NFI S-WAY 30 LHOD VALVE, 24 VDC	1
40	102263	0.575" NFI CHNTR CLOSURE 30 LHOD VALVE, 24 VDC	1
41	102270	0.230" S-WAY 30 LHOD VALVE, 24VDC/110VAC	5
42	102917	0.230 NFI F 0.230 OD PFC SWRFL FLOW	2
43	111249	PWR SUPPLY, 100-240, 24V, 100W	1
44	100039	STEEL AX GUARD FOR 409" AX	1
45	999799	DIN RAIL, 1.5 INCH	9

GENERAL NOTES:

(1) LEAVE 32" FLYING LEAD OF SHIELDED SIGNAL WIRE FOR MO 2 OPTIO N.

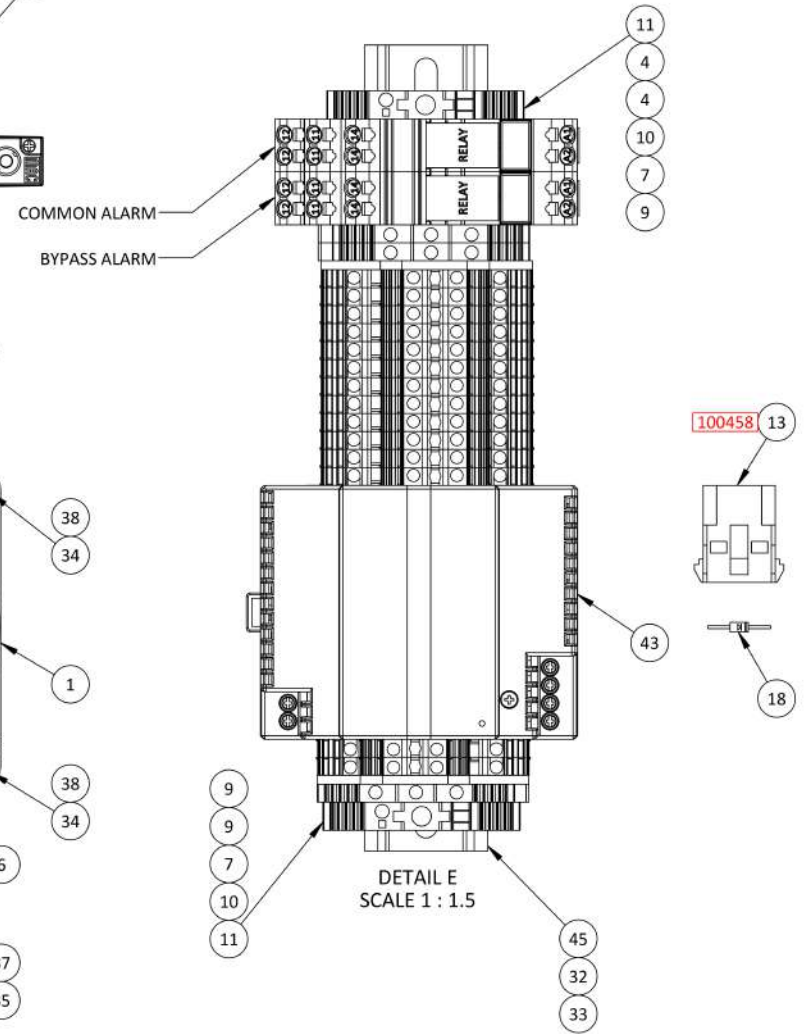
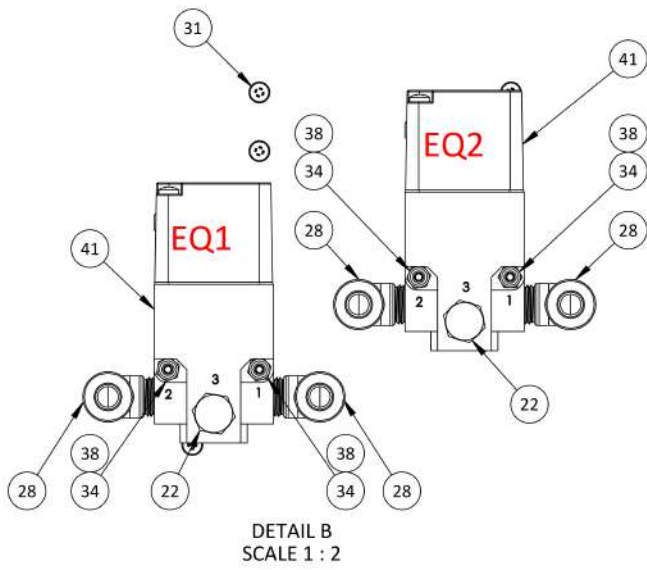
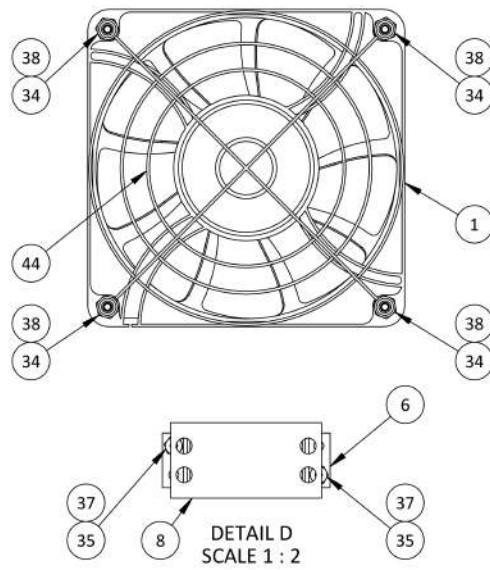
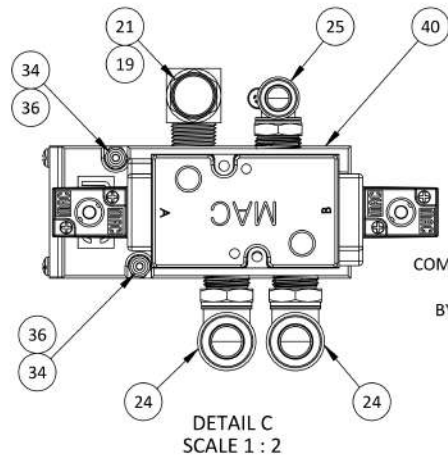
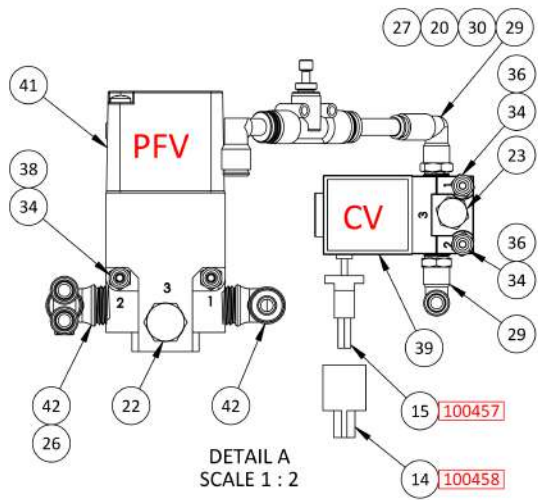

24 VDC

0V

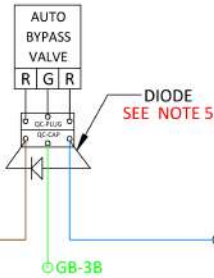
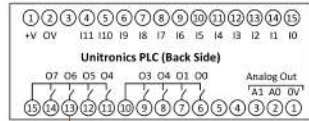

DIODE
SEE NOTE 5

SEE NOTE 4

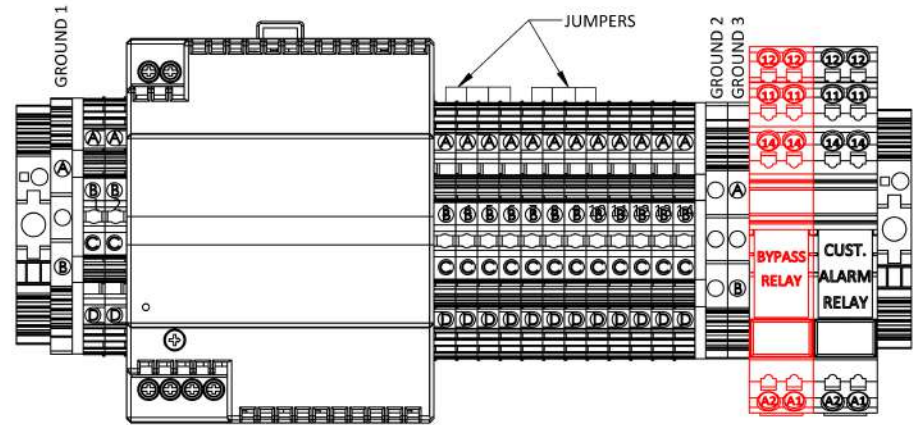
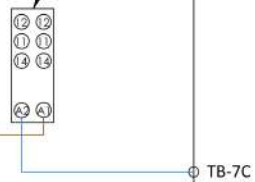

- GENERAL NOTES:**
- (1) TERMINAL BLOCKS 1 AND 2 OPEN FACE LEFT, GROUND 1 OPEN FACE RIGHT.
 - (2) TERMINAL BLOCKS 3-13 OPEN FACE RIGHT, GROUND 2 OPEN FACE LEFT.
 - (3) FERRITE CORE NEEDS TO BE INSTALLED WITHIN 2" OF TERMINAL AND WRAPPED A MIN. OF 2X.
 - (4) IF ALARM IS ACTIVE 11-14 WILL BE CLOSED AND 11-12 WILL BE OPEN.
 - (5) THE DIODE SHOULD BE CONNECTED AS NEAR TO THE SOLENOID AS POSSIBLE. THE CATHODE (STRIPED SIDE OF THE DIODE) SHOULD FACE THE HIGHER VOLTAGE END OF THE SOLENOID (24V).

WIRING TABLE			
AWG	COLOR	SERVICE	FIELD / INTERNAL
16-18	BROWN	24 VDC +	INTERNAL
16-18	BLUE	0V	INTERNAL
14-16	GREEN	GROUND	INTERNAL
16-22	GREY	SIGNAL	INTERNAL

24 VDC

0V

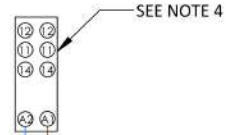
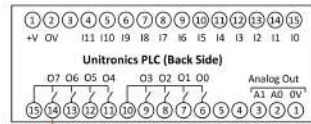

TB-8D

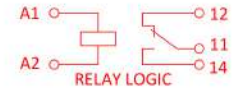
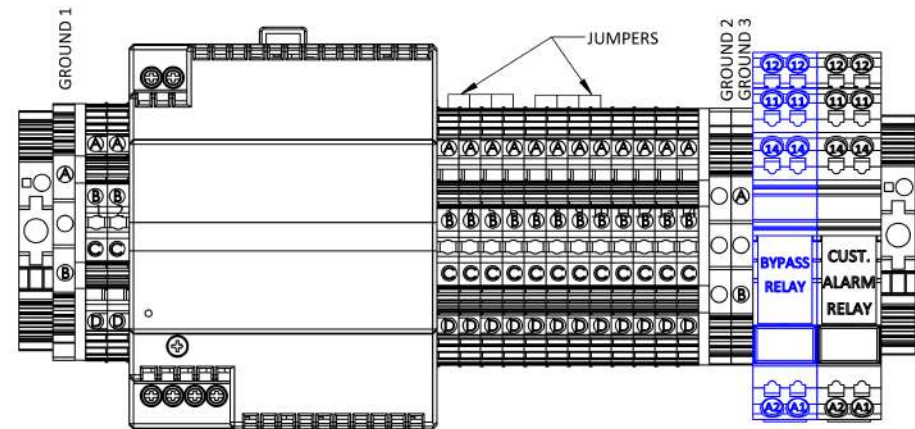

- GENERAL NOTES:
- (1) TERMINAL BLOCKS 1 AND 2 OPEN FACE LEFT, GROUND 1 OPEN FACE RIGHT.
 - (2) TERMINAL BLOCKS 3-13 OPEN FACE RIGHT, GROUND 2 OPEN FACE LEFT.
 - (3) FERRITE CORE NEEDS TO BE INSTALLED WITHIN 2" OF TERMINAL AND WRAPPED A MIN. OF 2X.
 - (4) IF ALARM IS ACTIVE 11-14 WILL BE CLOSED AND 11-12 WILL BE OPEN.

WIRING TABLE			
AWG	COLOR	SERVICE	FIELD / INTERNAL
16-18	BROWN	24 VDC +	INTERNAL
16-18	BLUE	0V	INTERNAL
16-22	GREY	SIGNAL	INTERNAL

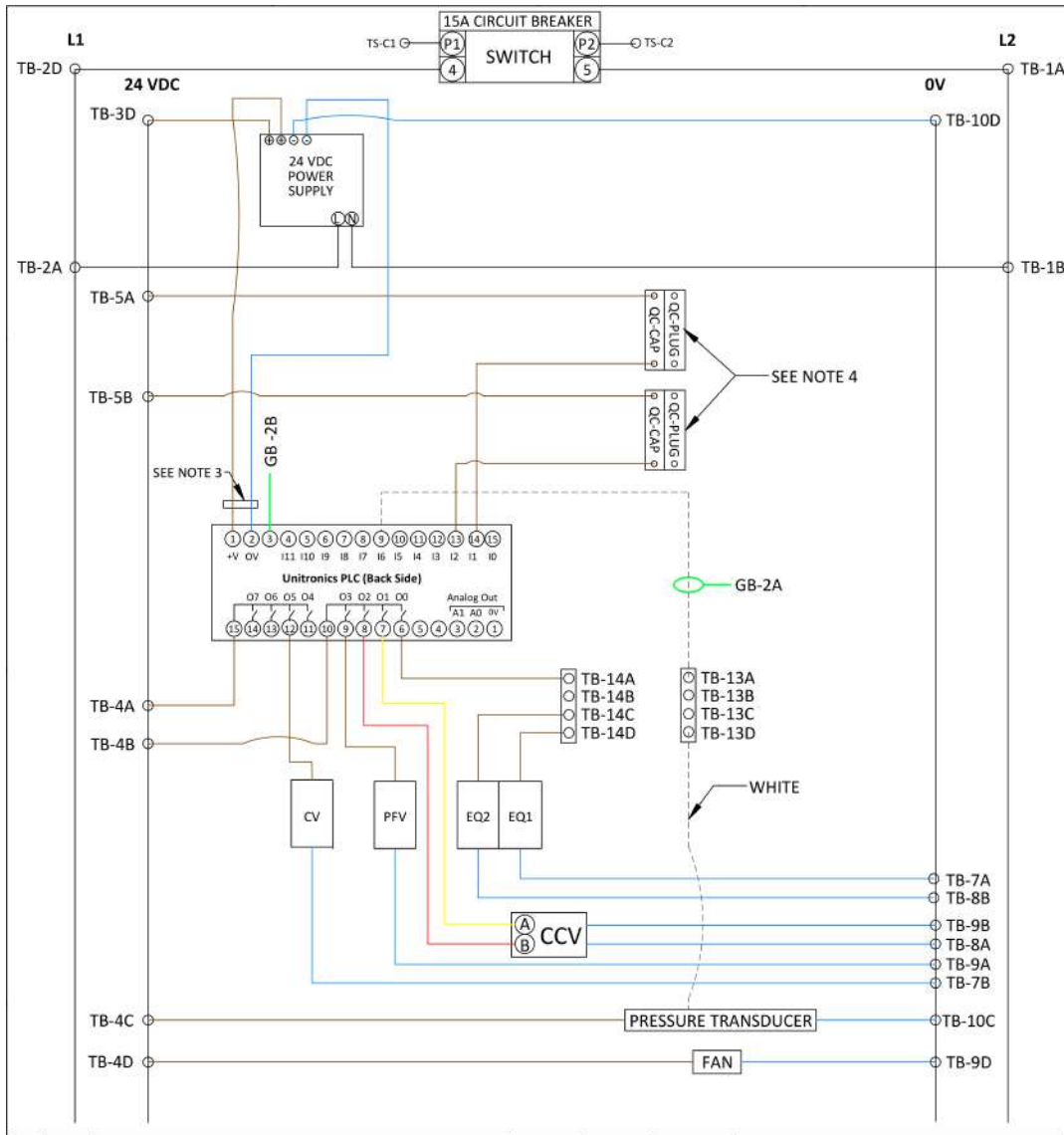

TYP5P ELECTRICAL CONN W CCV

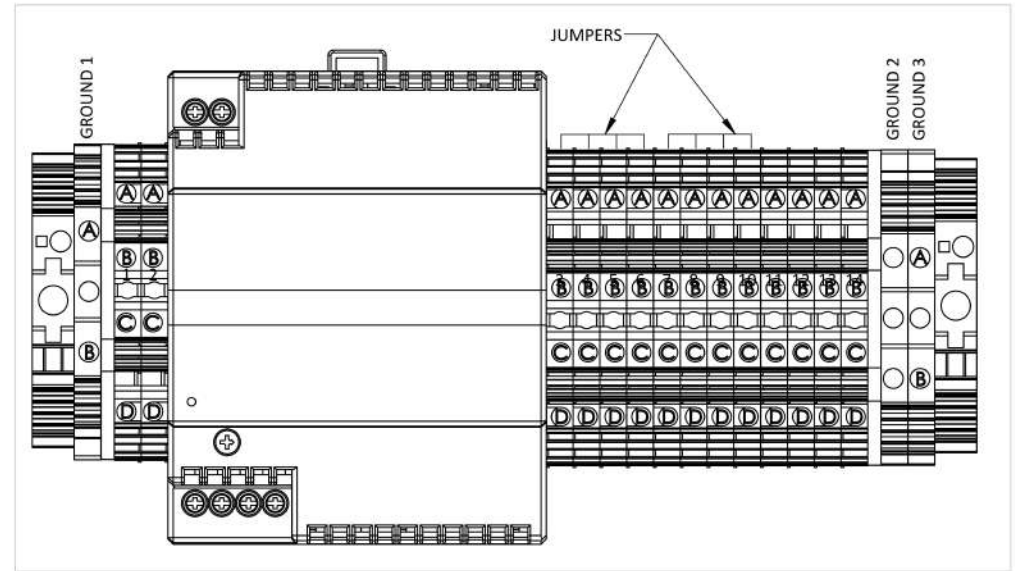

GENERAL NOTES:

- (1) TERMINAL BLOCKS 1 AND 2 OPEN FACE LEFT, GROUND 1 OPEN FACE RIGHT.
- (2) TERMINAL BLOCKS 3-13 OPEN FACE RIGHT, GROUND 2 OPEN FACE LEFT.
- (3) FERRITE CORE NEED TO BE INSTALLED WITHIN 2" OF TERMINAL AND WRAPPED A MIN. OF 2X.
- (4) PRE WIRED FOR EQUIPMENT ALARM.
- (5) PRODUCTS SUPPLY VOLTAGE IS FACTORY CONFIGURED AND MAY NOT BE CHANGED POST BUILD. STANDARD ELECTRICAL IS 110V. ALTERNATE VOLTAGE AVAILABLE IN -220 AND -CE PRODUCTS. SEE PRODUCT INFORMATION LABEL FOR CONFIRMATION OF SPECIFICATIONS.

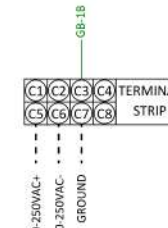

UNITRONICS PROGRAM:
(SEE PROJECT CHECKLIST
FOR CURRENT VERSION)

JUMPER SETTINGS:

- | | |
|-------|--------|
| 1 - B | 8 - B |
| 2 - B | 9 - A |
| 3 - B | 10 - A |
| 4 - B | 11 - A |
| 5 - A | 12 - B |
| 6 - A | 13 - A |
| 7 - A | 14 - A |

TORQUE SPECIFICATIONS	
ITEM	MIN - MAX
PLC	0.5 Nm MAX
POWER SUPPLY	0.67 Nm MAX

Wiring Table			
AWG	COLOR	SERVICE	FIELD / INTERNAL
14	CUST. CHOICE	110/220 VAC	FIELD
14	BLACK	110/220 VAC - L1	INTERNAL
14	WHITE	110/220 VAC - L2/N	INTERNAL
14	GREEN/YELLOW	GROUND	FIELD/INTERNAL
16-18	BROWN	24 VDC +	INTERNAL
16-18	BLUE	0V	INTERNAL
16-22	GREY	SIGNAL	INTERNAL

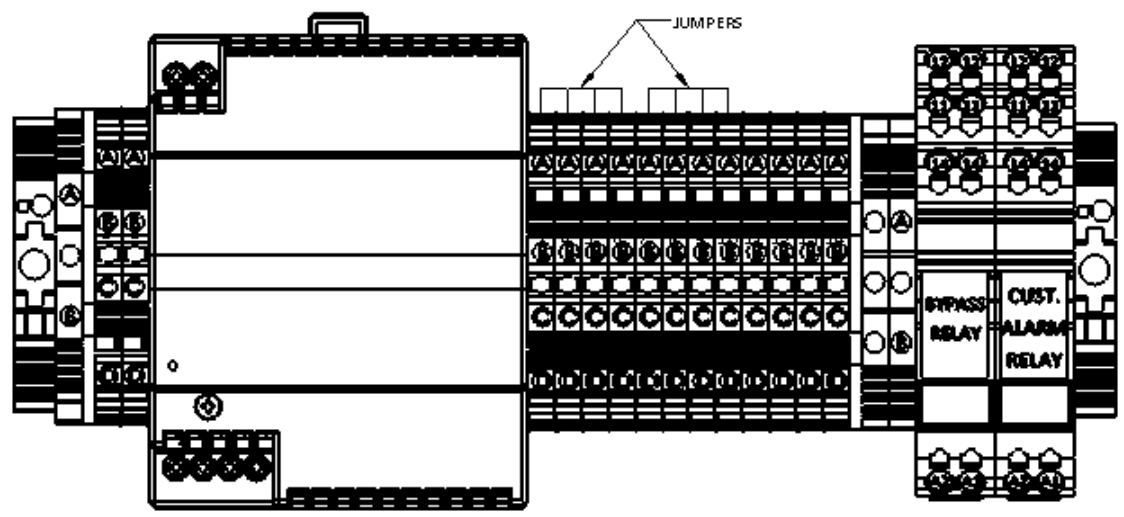
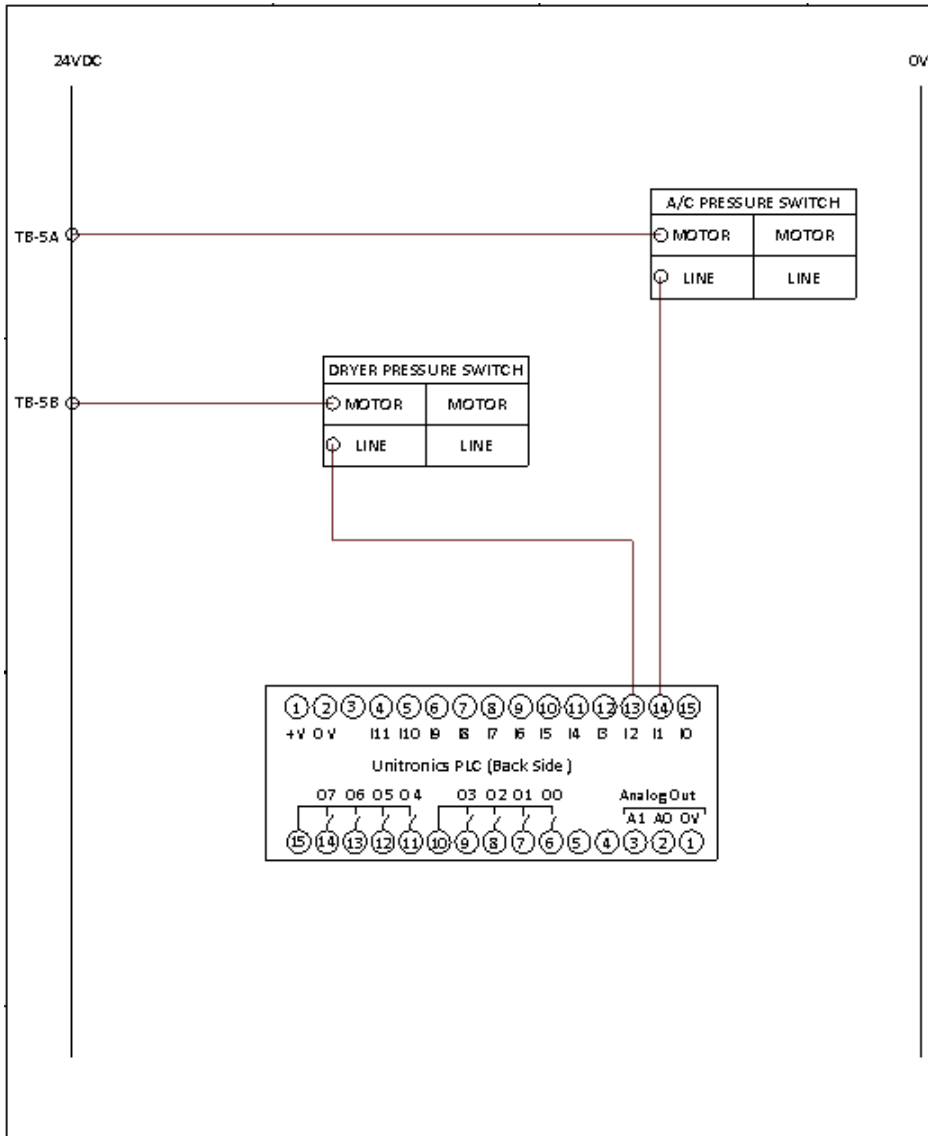

- GENERAL NOTES:**
- (1) TERMINAL BLOCKS 1 AND 2 OPEN FACE LEFT, GROUND 1 OPEN FACE RIGHT.
 - (2) TERMINAL BLOCKS 3-13 OPEN FACE RIGHT, GROUND 2 OPEN FACE LEFT.

WIRING TABLE			
AWG	COLOR	SERVICE	FIELD / INTERNAL
16-18	BROWN	24 VDC +	INTERNAL
16-18	BLUE	OV	INTERNAL
16-22	GREY	SIGNAL	INTERNAL

TYP5P ELECTRICAL CONNECTIONS

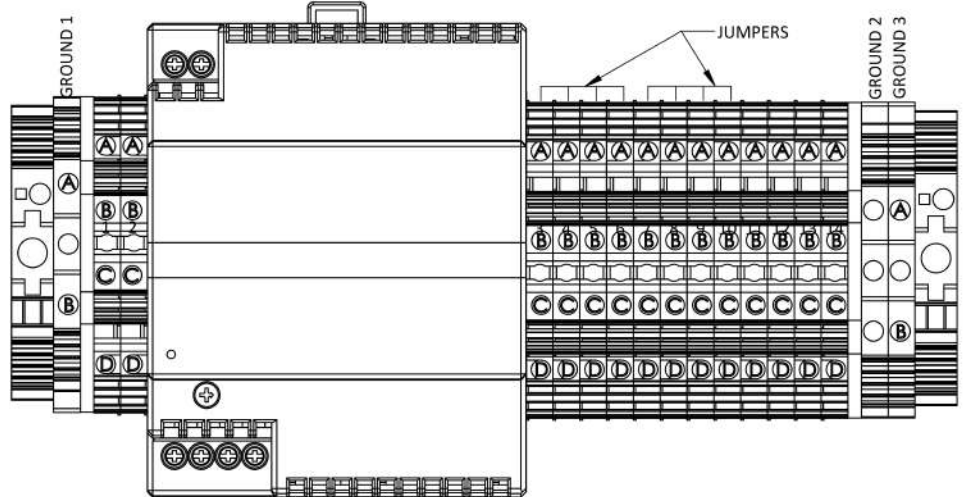
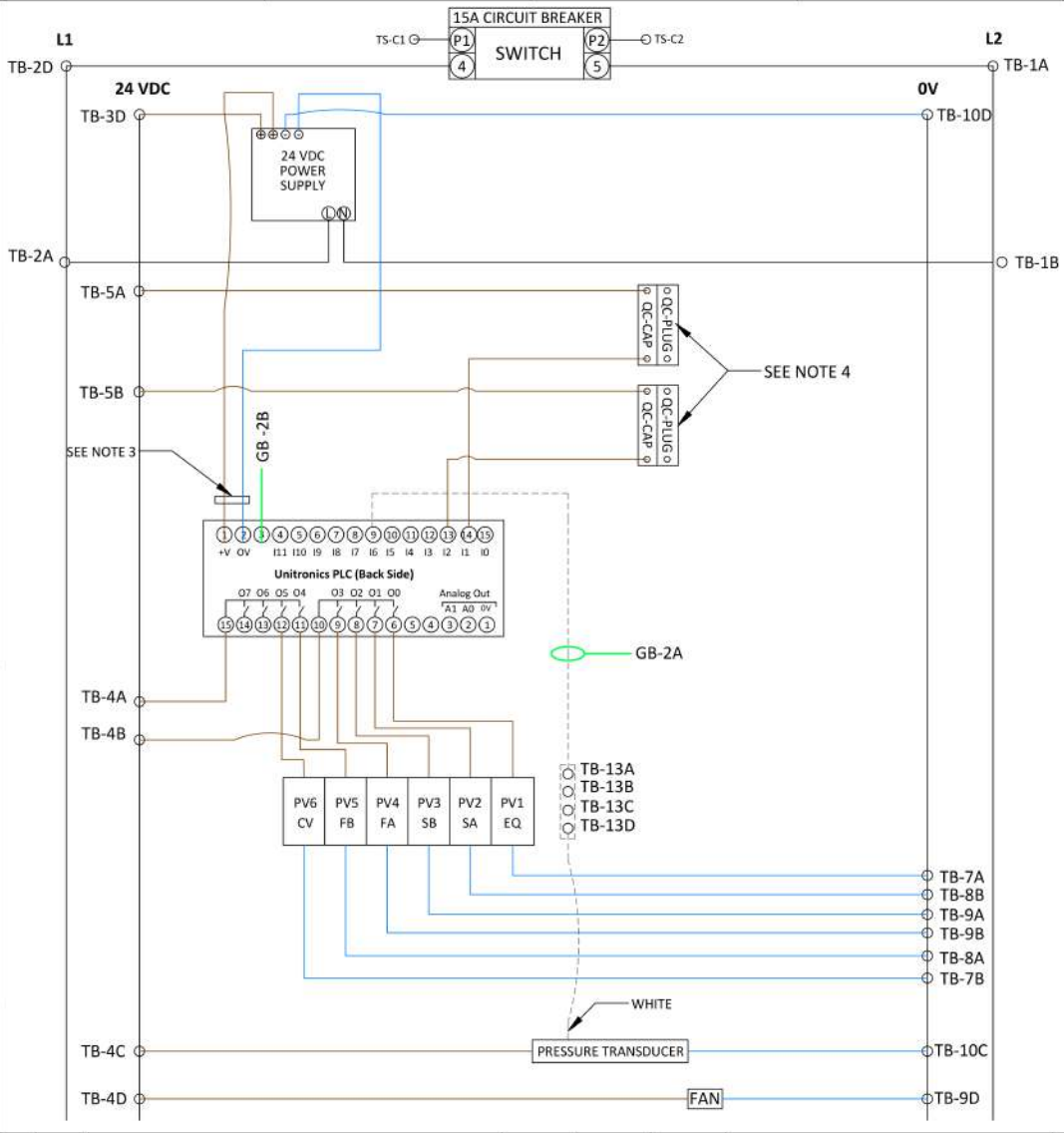

UNITRONICS PROGRAM:
(SEE PROJECT CHECKLIST FOR CURRENT VERSION)

JUMPER SETTINGS:

1 - B	8 - B
2 - B	9 - A
3 - B	10 - A
4 - B	11 - A
5 - A	12 - B
6 - A	13 - A
7 - A	14 - A

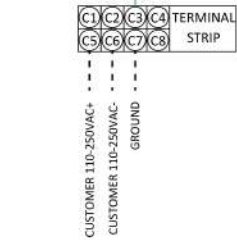

- GENERAL NOTES:**
- (1) TERMINAL BLOCKS 1 AND 2 OPEN FACE LEFT, GROUND 1 OPEN FACE RIGHT.
 - (2) TERMINAL BLOCKS 3-13 OPEN FACE RIGHT, GROUND 2 OPEN FACE LEFT.
 - (3) FERRITE CORE NEED TO BE INSTALLED WITHIN 2" OF TERMINAL AND WRAPPED A MIN. OF 2X.
 - (4) PRE WIRED FOR EQUIPMENT ALARM.
 - (5) PRODUCTS SUPPLY VOLTAGE IS FACTORY CONFIGURED AND MAY NOT BE CHANGED POST BUILD. STANDARD ELECTRICAL IS 110V. ALTERNATE VOLTAGE AVAILABLE IN -220 AND -CE PRODUCTS. SEE PRODUCT INFORMATION LABEL FOR CONFIRMATION OF SPECIFICATIONS.

		Wiring Table		
AWG	COLOR	SERVICE	FIELD / INTERNAL	
14	CUST. CHOICE	110/220 VAC	FIELD	
14	BLACK	110/220 VAC - L1	INTERNAL	
14	WHITE	110/220 VAC - L2/N	INTERNAL	
14	GREEN/YELLOW	GROUND	FIELD/INTERNAL	
TORQUE SPECIFICATIONS				
ITEM	MIN - MAX			
PLC	0.5 Nm MAX		16-18	BROWN
			16-18	BLUE
POWER SUPPLY	0.67 Nm MAX		16-22	GREY
				24 VDC +
				0V
				SIGNAL

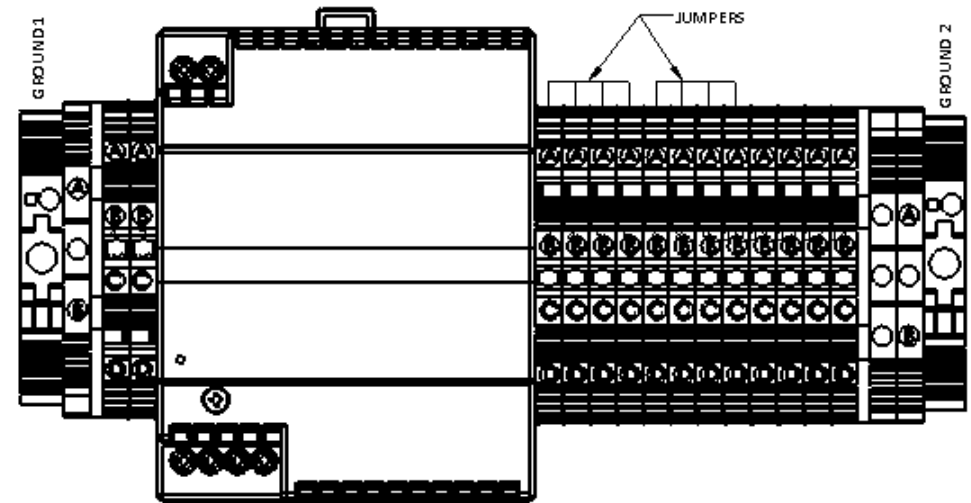
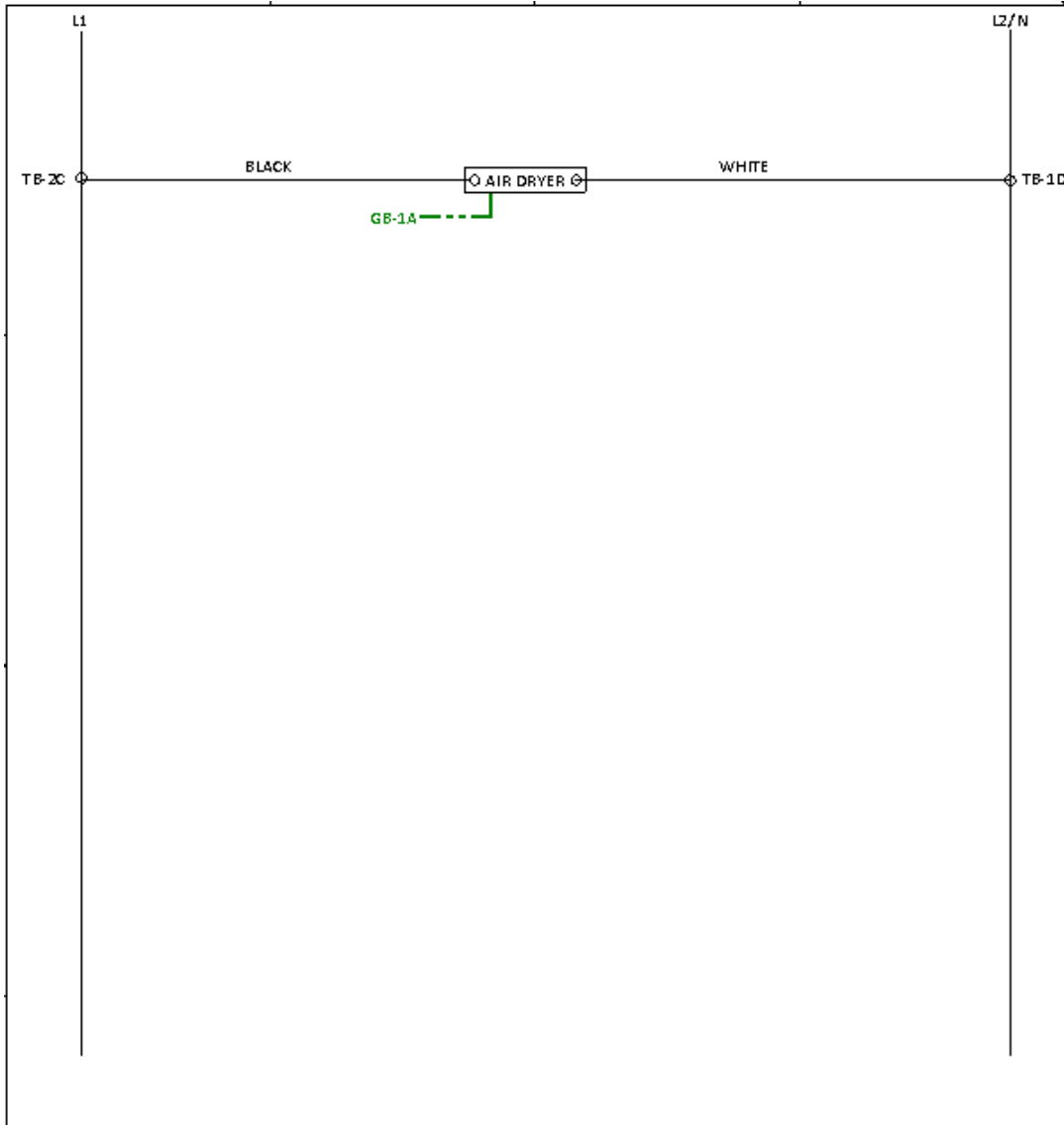

GENERAL NOTES:

- (1) TERMINAL BLOCKS 1 AND 2 OPEN FACE LEFT, GROUND 1 OPEN FACE RIGHT.
- (2) TERMINAL BLOCKS 3-13 OPEN FACE RIGHT, GROUND 2 OPEN FACE LEFT.
- (3) FERRITE CORE NEEDS TO BE INSTALLED WITHIN 2" OF TERMINAL AND WRAPPED A MIN. OF 2X.
- (4) MUST ENSURE THAT CORD FOR 110/220VAC DRYER CIRCUIT SEPARATED FROM 24 VDC BY 3 INCHES, CROSS PERPENDICULAR WHEN NECESSARY.

Wiring Table

AWG	COLOR	SERVICE	FIELD / INTERNAL
14	CUST. CHOICE	110/220 VAC	FIELD
14	BLACK	110/220 VAC- L1	INTERNAL
14	WHITE	110/220 VAC- L2/N	INTERNAL
14	GREEN	GROUND	FIELD/INTERNAL
16-18	BROWN	24 VDC +	INTERNAL
16-18	BLUE	0V	INTERNAL
16-22	GREY	SIGNAL	INTERNAL

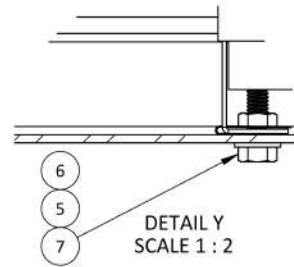
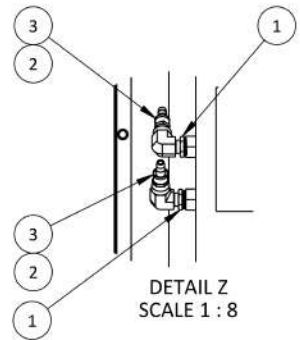
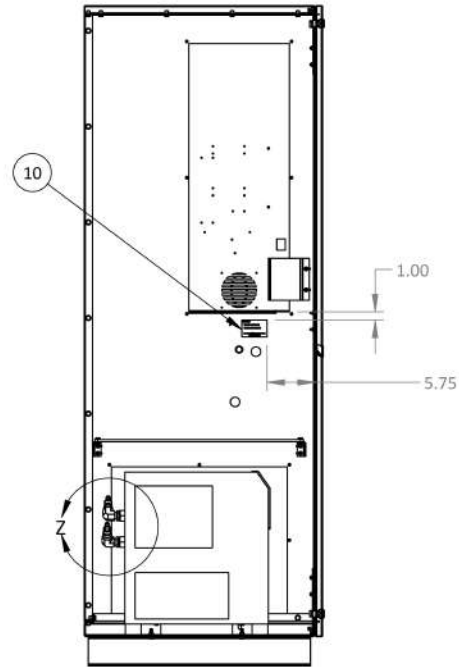
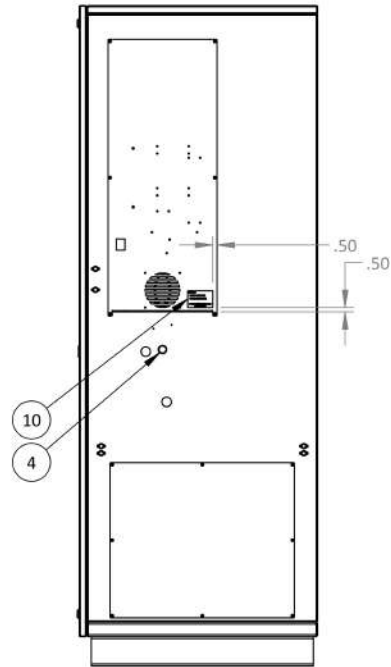
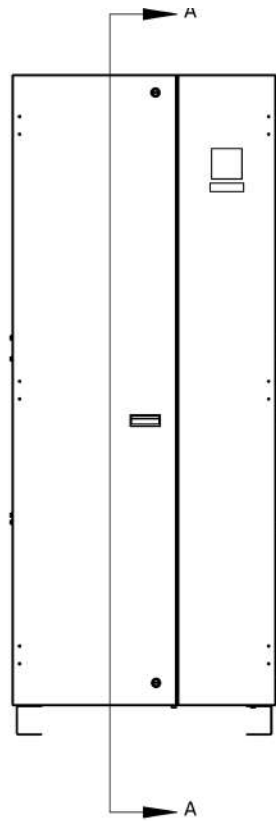

ITEM #	NUMBER	DESCRIPTION	QTY.
1	100985	0.750 NPT X 0.500 NPT BUSHING, BLACK	2
2	101267	0.500 NPT STREET ELBOW, PS	2
3	101995	0.500 NPT X 0.500 PUSH-ON BARB SWIVEL, PS	2
4	102569	0.875" PUSH-IN METAL PLUG	1
5	102614	0.3125 FLAT WASHER	4
6	102703	0.3125"-18 CLIP ON HEX NUT	4
7	102883	0.3125" X 01.000" HEX BOLT, FULL THREAD, ZINC PLATE, GRADE 8	4
8	103608	SMC REFRIGERATED DRYER, IDFB6E-11N	1
9	105221	SMART-TRAK LABEL	1
10	105527	SERIAL NUMBER LABEL	2
11	105858	TYP5P CABINET, RED	1

