

# BREW BLAST

110CPH

Quick-Start Guide

Version 0; 06/29/2018  
© 2020



*The Leader in Nitrogen Generation Technology*

## VERSION HISTORY

Revision #	Implemented By	Revision Date	Approved By	Approval Date	Reason
0	K. Mellott	7/2/2018	M. Thomas	07/02/18	Initial Release

BrewBlast™ 110CPH – Specifications	
Nitrogen Purity	99.7+%
Installation	Lockable Swivel Caster Wheels
Display	Hours / Run / Standby / Filter Alarm / BlastOff™
N <sub>2</sub> Storage Pressure	60-90 PSIG
Cabinet Port Connections	Industrial Quick Coupler with 1/4" MNPT Plug
Electrical	110V / 60Hz / 1Phase; 10A Fuse
Compressor	Integral / Oil-Free
Ambient Temperature	40° to 90°F
Noise Level (dbA)	< 85 dbA
Size	20" L x 9" W x 26" H (Cabinet Dimensions)

-----Notes-----

# TABLE OF CONTENTS

<b>1 INTRODUCTION.....</b>	<b>5</b>
1.1 Purpose.....	5
1.2 Audience .....	5
1.3 Important Information.....	5
<b>2 SAFETY GUIDELINES .....</b>	<b>6</b>
2.1 General.....	6
<b>3 INITIAL START-UP .....</b>	<b>7</b>
3.1 Electrical Connections .....	7
3.2 Nitrogen/Drain Connections.....	8
3.3 Turning on the Generator for the First Time .....	9
3.4 Starting & Stopping .....	10
<b>4 SYSTEM OPERATION .....</b>	<b>11</b>
4.1 Instructions.....	11
4.2 Alarms and Alarm Indicator Lights.....	11
<b>5 SYSTEM MAINTENANCE.....</b>	<b>13</b>

## **1 INTRODUCTION**

### **1.1 PURPOSE**

The BrewBlast™ 110CPH provides an economical, precise means of supplying nitrogen to “push” the cold brew coffee to the tap within café and coffee-serving establishments.

South-Tek System’s line of BrewBlast™ products consist of an internal N<sub>2</sub> generator and an integrated compressor. Since air is comprised of ~79% N<sub>2</sub> we simply and cost-effectively separate the N<sub>2</sub> from the air. Nitrogen is an inert gas (non-combustible), which is even used to package food products for increased shelf life. The N<sub>2</sub> is “generated” by our membrane technology, where compressed air is forced through a separation media and O<sub>2</sub> is exhausted to atmosphere and N<sub>2</sub> is allowed to pass through to process.

### **1.2 AUDIENCE**

This manual is intended for Installer/Restaurant/Bar Operator/Supervisory Staff and should be read in its entirety prior to operation.

Please contact your local provider for any operation and maintenance first prior to contacting the manufacturer.

### **1.3 IMPORTANT INFORMATION**

Before personnel attempt to service the unit, ensure the power switch has been turned to the off position, and then disconnect the unit’s external power cord from the building electrical power supply if possible. Always follow specific manuals from STS when servicing your system.

## 2 SAFETY GUIDELINES

### 2.1 GENERAL

Correct use of the BrewBlast™ 110CPH is important for your personal safety and for trouble-free functioning of the BrewBlast™ 110CPH. Incorrect use can cause damage to the BrewBlast™ 110CPH or can lead to incorrect gas supply.

The BrewBlast™ 110CPH produces Nitrogen (N<sub>2</sub>) at a low flow rate, which quickly dissipates into the air. N<sub>2</sub> gas is not poisonous but it should not be directly inhaled, since in high concentrations, it can cause asphyxiation. **Ensure that the unit is installed within a well-ventilated room, one that is not sealed off from normal living space air changes.**

Install with at least 6" of open space on either side to allow for proper ventilation of the nitrogen generator. Blocking vents can cause excess heat to build in the nitrogen generator cabinet.

All personnel involved with installation, operations, and maintenance of the BrewBlast™ 110CPH must follow safe working practices, OSHA, and local health/safety code regulations during the installation, operation, and maintenance of the unit.

**Warning:**

**This guide must be read in its entirety prior to installing and operating the BrewBlast™ 110CPH to prevent accidents and damage to the BrewBlast™ 110CPH.**

**Contact your supplier if you detect a problem that you cannot solve with this manual.**

**Only use the BrewBlast™ 110CPH in accordance with its designed purpose.**

**Only service-engineers, that are qualified to work on electric and pneumatic equipment, are allowed to do the installation, maintenance, and repairs. Unqualified people are not allowed to repair the equipment.**

**Do not tamper or experiment with the equipment or exceed the technical specifications**

### 3 INITIAL START-UP

#### 3.1 ELECTRICAL CONNECTIONS

Connect the power cord supplied with the BrewBlast™ 110CPH to the plug on the back of the system labeled “Power Supply” and plug the opposite end into a standard 120VAC/60Hz/1Ø wall receptacle (preferably a designated small appliance circuit).



#### Customer Alarm

These connections are for remote monitoring of the equipment, they can be used to connect to an audible or visual alarm indicator or run to a building management device. These contacts are rated for a maximum of 1A at 5-27VDC/5-240VAC. Follow local and site regulations when wiring these

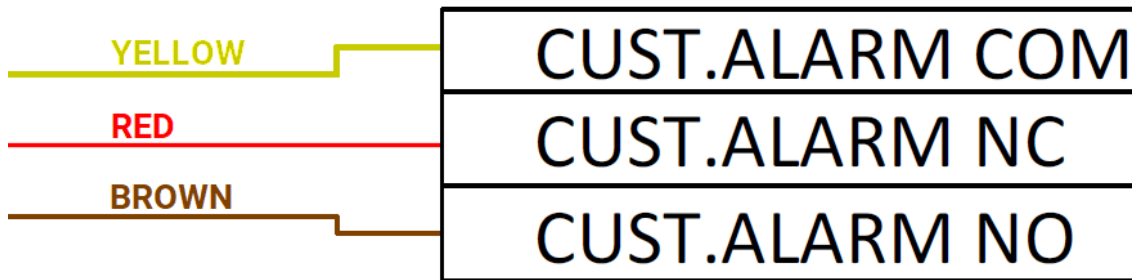

connections.

The yellow wire acts as the common which will supply power to the NO or NC depending on alarm status. If an alarm is triggered, including BlastOff™, filter replacement, and compressor replacement, the COM and NO will be connected, and the COM and NC will be disconnected. The NC connection (red) also acts as a power loss indicator, it will signal if the generator is unplugged or accidentally turned off.

### 3.2 NITROGEN/DRAIN CONNECTIONS

The outlet nitrogen port is a standard industrial quick coupler for connection to normal air hoses. A ¼" MNPT quick coupler plug is also included for connection with ¼" NPT hoses and piping.

Connect by pushing the sleeve on the nitrogen outlet quick coupler while pushing the quick coupler plug into the coupler. Once in place, release the quick coupler sleeve to lock the plug into the coupler.



The condensate drain connection is a ¼" OD push-to-connect fitting, this fitting can be connected to an external drain to drain off the water accumulated in the filter bowls. The filter bowls drain automatically when enough water has amassed in the bottom of the bowls.

To locate the drain connection, see figure on the next page.



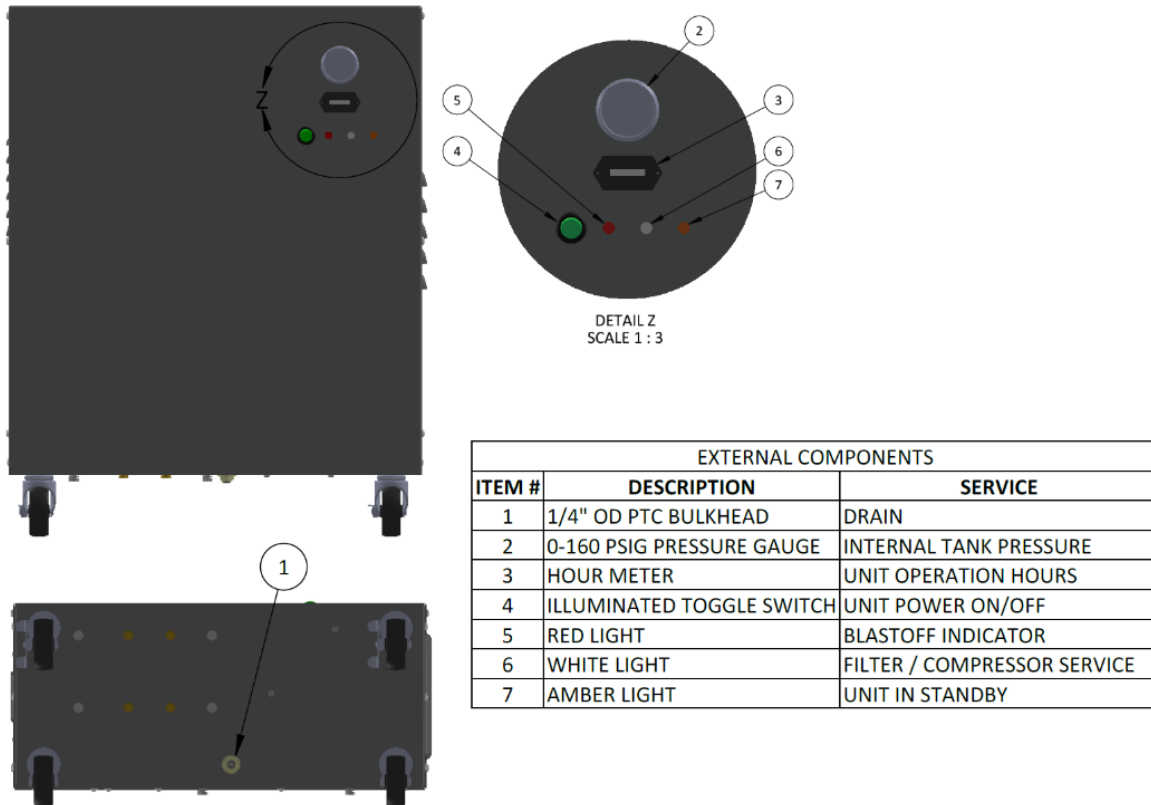

### 3.3 TURNING ON THE GENERATOR FOR THE FIRST TIME

- To start the generator once electrical and plumbing connections are made, simply push the green power switch on the front of the generator to the ON(up) position.

**Note: On startup the generator will have a 12 second delay before the compressor operates. This is designed to prevent damage to the compressor.**

- At this point the power switch should be illuminated designating the system is operating and the generator will start filling the internal storage tank.
- It is suggested that the system plumbing leading to the cold brew system be purged with the nitrogen being generated in the initial start-up for at least 15 minutes to ensure the best purity of nitrogen for pouring.
- Watch the system fill and fix any leaks determined down stream of the nitrogen generator. Leaks can cause excessive run times and wear on components.
- Once the storage tank is full (~90 PSIG) the generator will shut off and go into standby (amber light will be illuminated).

- After the nitrogen storage tank is depleted down to the cut-in pressure (~60 PSIG) the generator will turn back on and refill the system.



### 3.4 STARTING & STOPPING

- To start the generator simply push the green power switch on the front of the generator to the ON(up) position.

**Note: On startup the generator will have a 12 second delay before the compressor operates. This is designed to prevent damage to the compressor.**

- At this point the power switch will be illuminated and the generator will be operating normally.

- The system has two main run modes – Run and Standby. When the green

(Operate) power switch is turned on and illuminated, the internal controller will automatically determine which mode to enter.

- If the BrewBlast™ is in run mode, the standby light will be off and the nitrogen generator will be filling the storage tank with nitrogen.
- If the BrewBlast™ is in standby mode, the standby light will be illuminated; the nitrogen generator will be off and waiting until the storage tank pressure drops the cut-in pressure to turn back on.
- If the BrewBlast™ 110CPH runs continuously for more than 9 hours, the BlastOff Alarm will shut down the generator (see: **4.2** for more details)

## 4 SYSTEM OPERATION

### 4.1 INSTRUCTIONS

The BrewBlast™ 110CPH is intended to be used to generate nitrogen to push coffee out of the keg. Follow the installation instructions above and only use in an approved environment. The generator generates enough nitrogen to push 110 cups per hour. Make sure that proper regulators, cooler temperature, and line temperatures are maintained, otherwise you will not be able to effectively push the coffee from the keg. Please consult with your local provider for questions not answered in this manual.

The system is design for 24-hour operation, but routine maintenance on the filters must be performed. See section “System Maintenance” for detail maintenance instructions.

### 4.2 ALARMS AND ALARM INDICATOR LIGHTS

#### Filter Alarm:

All BrewBlast™ 110CPH comes standard with a Filter Alarm notification. The “Alarm” indicator light will illuminate continuously when the filter change is overdue. It is recommended that the filters be changed once every year or whenever the filter replacement light comes on (every 1000 hours of run time), whichever comes first. See section “System Maintenance” for detail maintenance instructions.

To reset the filter alarm after changing out the filter elements, whether the filter alarm has been triggered or not, press and hold the black and silver “Alarm Reset

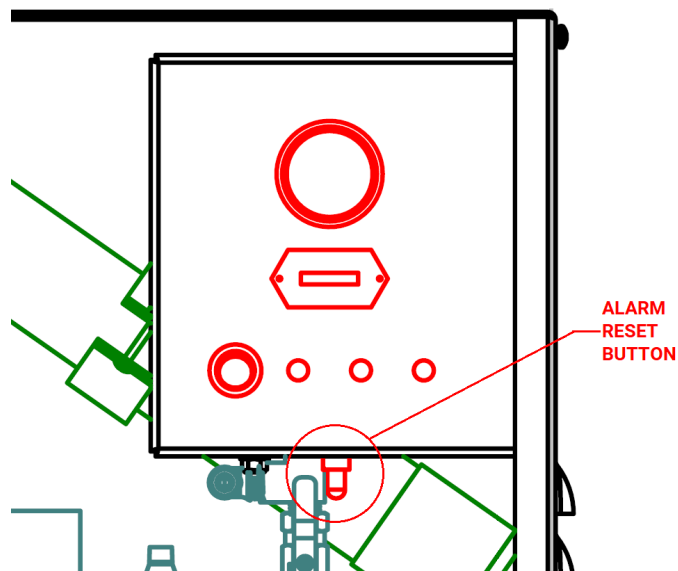

Button” on the inside of the nitrogen generator until the “Alarm” indicator light flashes confirming the 1000-hour run timer has been reset.

BlastOff™ Alarm:

Included with the system is the BlastOff™ - Leak Detection System. It is a patented system in the BrewBlast™ 110CPH that detects line leaks within the downstream gas lines from the N2 Generator to the kegs. Line leaks could be due to a keg not being tapped correctly, a gas line leak, or fitting therein failing, etc. These leaks are potential safety hazards, can be the precursor to a rupture in the lines, and could also cause your BrewBlast™ 110CPH to run in excess (decreasing the life of the unit).

Once a leak has been detected, the BlastOff™ illuminates the “BlastOff” light in red on the control panel and shuts down the BrewBlast™ 110CPH until the problem has been remedied and the alarm has been reset. To reset the BlastOff™, simply turn off the BrewBlast™ 110CPH using the green toggle switch and turn it back on.

Never reset repeatedly; if the BlastOff™ goes off daily, there is a real potential issue. Consult your installer for a solution.

Compressor Maintenance Alarm:

The BrewBlast™ 110CPH also comes fitted with a compressor maintenance/replacement warning. The integrated compressor generally has a lifespan of around 8000-12000 run hours or more with regular maintenance. When the compressor is nearing the end of its lifecycle, the “Alarm” indicator will flash on and off.

After a new compressor has been installed this alarm can be reset by pressing the “Alarm Reset Button” three times in quick succession.

## 5 SYSTEM MAINTENANCE

Whenever doing any maintenance to the system, make sure to power down the system. Remove the front cover to gain access to the filters and alarm reset button.

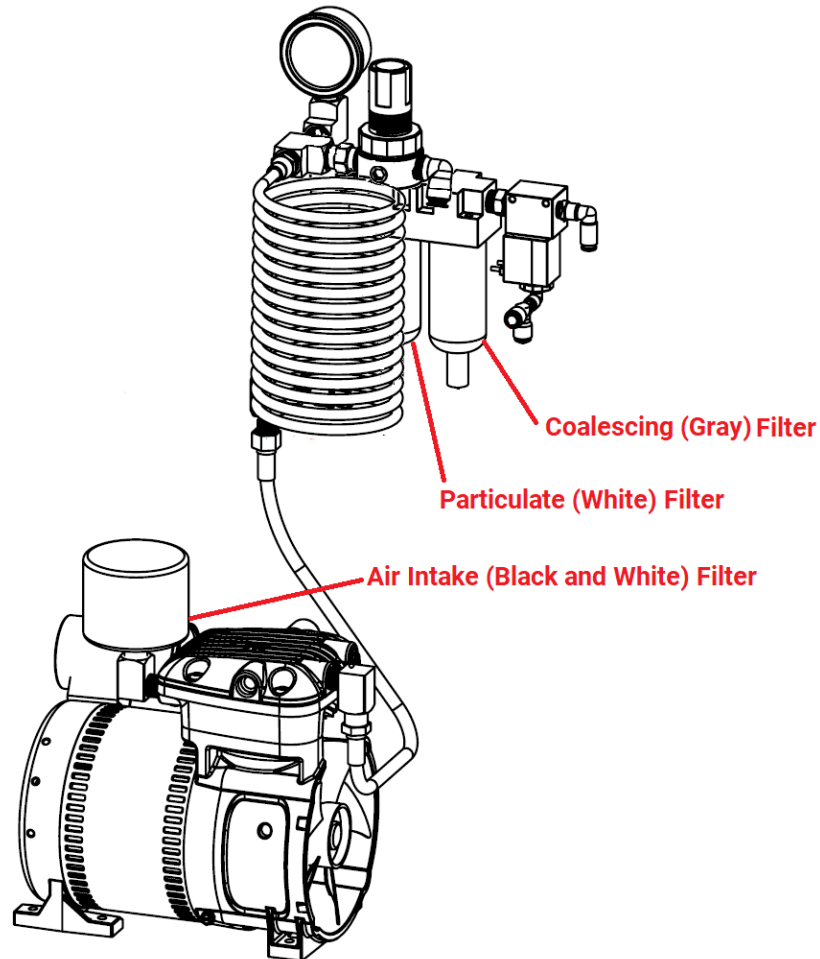

### Annual Filter replacement kit part # FRP-001

#### Air Intake Filter

The integrated air compressor has an air intake filter mounted on top. It is design to prevent particles from entering into the compressor housing and damaging internal components. This filter needs to be replaced once per year or every 1000 hours, whichever comes first. To do so, remove the air intake filter cap by twisting it clockwise. Remove the old element and use a

clean dry cloth to clean the filter enclosure before installing the new element.

### Particulate and Coalescing Filter

The particulate and coalescing filter after the air compressor is designed to capture particulate and moisture prior to entering the rest of the system. These filters need to be replaced once per year or every 1000 hours, whichever comes first. To do so,

1. Make sure there is no pressure on the filter bowls. The gauge on the filter assembly will read 0 PSIG to indicate that there is no pressure on the bowl.
2. Unscrew the filter bowls by turning them counter-clockwise.
3. Once the filter bowls have been removed, rinse any debris out of the bowls with warm water.
4. Dry the bowls with a clean dry cloth and replace the old O-rings with the ones provided in the kit.
5. Pull the black plastic element holder out of the filter bowl. Carefully twist the two sides of the black plastic cover apart and pull out the white particulate filter element. Install the new element in the reverse order.
6. The coalescing element can be removed by turning it counter-clockwise by hand; install the new element in the reverse order.
7. Once both elements have been replaced, bowls have been cleaned and O-rings replaced, the bowls can be screwed back in to their corresponding filter housings.

Once all the filters have been replaced, press and hold the filter reset button on the control panel until the "Alarm" indicator light blinks confirming the 1000-hour run timer has been reset. Put the front cover back on the cabinet and power up the nitrogen generator. Once powered up, the BrewBlast™ 110CPH will be producing nitrogen when needed.

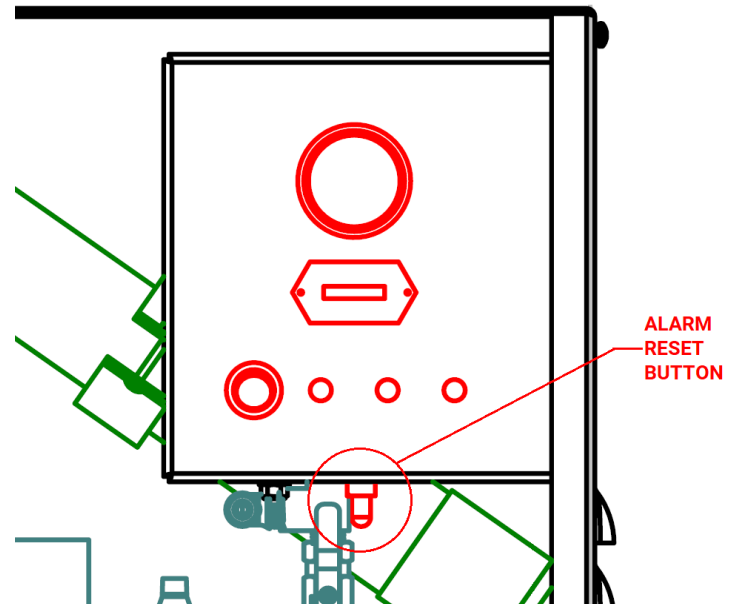

## APPENDIX A: WARRANTY

The BrewBlast™ 110CPH System is warrantied against any defects in workmanship and materials for 12 months (or 1000 hours) from the date of shipment from South-Tek Systems, whichever comes first. The purchaser has the liability to ensure that the system is fully inspected upon delivery and shall contact the appropriate shipping company to make any claims on damaged goods due to transit within that shipping company's policies. If the system is received with defects that are not due to shipping, a written claim should be submitted to South-Tek Systems within 1 week of receiving the shipment. South-Tek Systems can deny all other claims at their discretion.

All warranty work shall be done at a South-Tek System facility or at a BrewBlast™ 110CPH Authorized Service Center. Only factory trained and authorized personnel are covered under warranty. Any part that is returned / repaired / replaced under warranty may be remanufactured or changed to a different specification at the factory's option. Any work performed by an unauthorized person/company or usage of non-factory parts, may void all warranties to the product.

Any item not manufactured by South-Tek may carry its own warranty from its manufacturer and will be warrantied by that manufacturer. All parts that need to be returned should be announced. Any item(s) that is returned to South-Tek Systems without an RMA number (return authorization number) may be denied and returned to the sender. Contact the factory for RMA #'s, prior to return shipment.

South-Tek Systems is not liable for damages caused by normal wear and tear, water, fire, erosion, corrosion, explosion, misuse, oil/gas vapors or unauthorized modifications. South-Tek Systems is also not liable for any losses, damages, or cost of delays, including incidental or consequential damages. There are no warranties or guarantees, expressed or implied, including the warranties of merchantability or fitness for a particular purpose or use, other than those warranties expressed herein.

For Claims, contact South-Tek Systems LLC at:

Tel: (888) 526-6284

Fax: (910) 332-4178

Email: [service@southteksystems.com](mailto:service@southteksystems.com)

Or write to:

South-Tek Systems, Warranty Claims,  
2940 Orville Wright Way,



Wilmington,

NC

28405

-----Last Page-----