

# DEOX FPS 1 CORROSION INHIBITING SYSTEM O&M MANUAL

Revision 2  
Date 02/04/16



## REVISION HISTORY

Revision #	Revision Date	Approved By	Approval Date	Reason
0	2/27/15	J. Nguyen	3/2/15	Initial Release
1	5/28/15	J. Nguyen	6/8/15	Updated Deox Design
2	2/4/16	J. Nguyen	2/9/16	Updated Deox Design

# TABLE OF CONTENTS

**1 INTRODUCTION.....5**

    1.1 Purpose .....5

    1.2 Audience.....5

    1.3 Important Information .....6

**2 SAFETY GUIDELINES.....7**

    2.1 General .....7

**3 SYSTEM OVERVIEW.....8**

    3.1 Key Features.....8

    3.2 Specifications .....11

**4 PRODUCT INSTALLATION .....12**

    4.1 Unpacking and Preparation .....12

    4.2 Electrical Requirements .....12

    4.3 Installation.....13

    4.4 Nitrogen Supply To The System.....16

**5 SYSTEM OPERATIONS.....17**

    5.1 Process 1: Purging The FPS Piping To >98% N<sub>2</sub> .....18

    5.2 Process 2: Filling Fire Protection Zone With Deox Water .....19

    5.3 Process 3: Drying The DeOx™ Contactor .....21

**6 SYSTEM USAGE .....22**

    6.1 Instructions .....22

    6.2 DeOx™ O<sub>2</sub> Meter.....22

**7 SYSTEM MAINTENANCE.....23**

    7.1 Water Filter Bag Replacement .....23

    7.2 Drying Deox Contactor .....23

**8 KEY CONTACTS.....23**

**9 FAQs .....24**

**APPENDIX A: WARRANTY.....25**

**APPENDIX B: GENERAL ARRANGEMENT DRAWINGS .....26**

-----Notes-----

# 1 INTRODUCTION

## 1.1 PURPOSE

Wet sprinkler systems experience interior pipe wall corrosion as a result of the oxygen-water interface, which occurs at high points within the piping. There's one way to put this problem to rest – by introducing 99.5%+ Nitrogen and DeOxygenated water into the sprinkler system. This effectively reduces internal corrosion and the costs stemming from premature pipe failure.

Sprinkler systems are charged with highly oxygenated water, a process that traps air (containing 20.9% oxygen) at high points throughout the piping. The resulting Oxygen-Water interface on the steel piping creates ideal conditions for corrosion. The Patent Pending DeOx™ FPS 1 Corrosion Inhibiting System inhibits corrosion in two ways. It eliminates trapped air pockets with an initial purge of > 99.5% pure Nitrogen, then introduces DeOxygenated (Deox) water (< 1.0 PPM) - the key to inhibiting corrosion in Wet Sprinkler Piping.

The following benefits includes:

- Easily integrates into new or pre-existing FPS
- Targets both aerobic and anaerobic bacteria
- Filters particulates removes impurities from fill water
- Reduces dissolved oxygen content from 10 PPM to < 1.0 PPM
- Water containing 1.0 PPM or less Oxygen inhibits the corrosion reaction
- Reduces the problematic oxygen-water interface
- Protects installation & extends life of sprinkler piping

The DeOx™ FPS 1 Corrosion Inhibiting System is setup to pre-fill the FPS piping with > 99.5% N<sub>2</sub> and then deliver Deox water with < 0.3 PPM O<sub>2</sub>. The pre-filling of N<sub>2</sub> will minimize the presence of O<sub>2</sub> in the pipes if gas pockets occur during the filling process. Having a low O<sub>2</sub> content in the sprinkler piping will reduce the chances of the O<sub>2</sub> content rising in the water due to Henry's law. Low O<sub>2</sub> content in the water will drastically reduce/eliminate the corrosion and leakage in the pipes. Typical O<sub>2</sub> content in city water is 9 PPM and upwards of 30 PPM under pressure.

## 1.2 AUDIENCE

This manual is intended for Fire Sprinkler Contractors and Building Maintenance Staff members and should be read in its entirety prior to operation.

Please contact your local Fire Sprinkler Contractor representative for any operation and maintenance questions not covered in this manual.

### **1.3 IMPORTANT INFORMATION**

Before personnel attempt to service the unit, ensure that the DeOx™ system is fully drained and depressurized. Always follow manuals and instructions from STS when servicing your system.

#### **PROTECTING THE DEOX™ SYSTEM**

- Change the water filter before every use
- Always open valves slowly to avoid water hammering
- Do not operate above the specified pressure or temperature ratings
- Avoid dropping or hitting the DeOx™ contactor
- Always dry the system if it is not in use (See 5.3 Process 3: Drying The DeOx™ Contactor)

Operating outside of these guidelines can negatively impact the system life and/or void the performance warranty that may exist. If you have questions about the system, please contact your local Fire Sprinkler Contractor representative.

## 2 SAFETY GUIDELINES

### 2.1 GENERAL

Correct use of the DeOx™ FPS 1 Corrosion Inhibiting System is important for your personal safety and for trouble-free functioning of the DeOx™ FPS 1 Corrosion Inhibiting System. Incorrect use can cause damage to the DeOx™ FPS 1 Corrosion Inhibiting System or may reduce the overall performance.

While the DeOx™ FPS 1 Corrosion Inhibiting System does not require any electrical power, it is recommended to not install near other equipment that is sensitive to exposure of water.

Be aware, that the system may be pressurized during different phases of the process. It is equipped with a pressure relief valve in case of over pressurization of the unit. Always check the gauges to see if there is pressure on the system before doing any maintenance. Open valves slowly to minimize impactful fluid hammering. Also, the system may be hooked up to a cryogenic N<sub>2</sub> source which can cause freezing temperatures on the surfaces of the system. Never flow more than the flowrate specifications of the cryogenic tank due to possible freezing of the lines. Always use caution when making physical contact with the unit.

All personnel involved with installation, operations, and maintenance of the DeOx™ FPS 1 Corrosion Inhibiting System must follow safe working practices, OSHA, and local health/safety code regulations during the installation, operation, and maintenance of the unit.

**Warning:**

- **This manual shall be read in its entirety before installing and operating the DeOx™ FPS 1 Corrosion Inhibiting System to prevent accidents and damage.**
- **Contact your local Fire Sprinkler Contractor if you detect a problem that you cannot solve with this manual.**
- **Only use the system in accordance with its designed purpose.**
- **Only service-engineers, that are qualified to work on the FPS piping system, are permitted to perform installation, maintenance and repairs. Work performed by unqualified persons shall result in a voided warranty.**
- **Do not tamper with, experiment on, or exceed the technical specifications of the equipment.**

### 3 SYSTEM OVERVIEW

The DeOx™ FPS 1 Corrosion Inhibiting System is intended to deliver Deox water at a specification of 300 PPM O<sub>2</sub> or less. It is designed to keep the water at low PPM levels once introduced to the sprinkler pipes by pre-filling the piping with high nitrogen concentration levels. This process minimizes O<sub>2</sub> in the gas pockets collating back into the water. The overall quality of the system requires proper pitching to reduce pockets and standard maintenance practices should be utilized prior to installation.

South-Tek's DeOx™ FPS 1 Corrosion Inhibiting System is specifically designed to deliver high quality deoxygenated water into wet fire sprinkler systems. It is fully assembled and ready to use once the proper connections are made. All systems come standard with pressure gauges, gas and liquid flowmeter, DeOx™ contactor, safety relief valve, and water filtration.

#### 3.1 KEY FEATURES

The DeOx™ FPS 1 Corrosion Inhibiting System key features include the following:

- Water filter
- Pressure Gauges
- Safety Relief Valve
- Water Flow Controller and Water Flow meter
- DeOx™ contactor
- Nitrogen Gas Flow Controller
- Drains

##### Water Filter:

The water filter is designed to keep large particles from entering into the Deox Contactor and causing damage. It is recommended to change out the bag filter (STS Part # 004-342-A) at the start of a new Deox water filling process. The start of a new Deox water filling process is defined as the first time water is introduced to the system after it has been through the contactor drying process.

##### Pressure Gauges:

The system includes incoming and outgoing water pressure gauges. If a pressure drop greater than 10 psig is observed, replace the water filter. If replacing the filter does not resolve the pressure drop issue, contact your local Fire Sprinkler Contractor.

##### Safety Relief Valves:

ASME rated Safety Relief Valves are designed into the system to minimize failure of other components. Pressure is set to 85 PSIG. Do not tamper with or adjust set pressure.



Water Flow Controller:

A globe valve and water flow meter is installed to tune the system to the correct specification. The specific tuning parameters will be provided by the installation team. Contact your local Fire Sprinkler Contractor Representative if that information was not provided during startup or if it was lost.

DeOx Contactor:

The Deox Contactor is designed and sized to meet specific zone requirements. Regular maintenance and proper care is required for optimal life. See section **7.2 Drying Deox** for detailed instructions.

Gas Flow Controller:

A gas regulator and flow metering system are installed to tune the system to the correct specification. Contact your local Fire Sprinkler Contractor if that information was not provided during startup or if it was lost. That information can be recorded in the blank “Notes Page” at the beginning of this manual for future reference.

Drains:

Drains are installed on the system to relieve the water and to dry out the membranes. Always make sure that these drains are plumbed to a suitable wet drain capable of handling up to 20 gallons per minute. Keep away from water sensitive equipment.

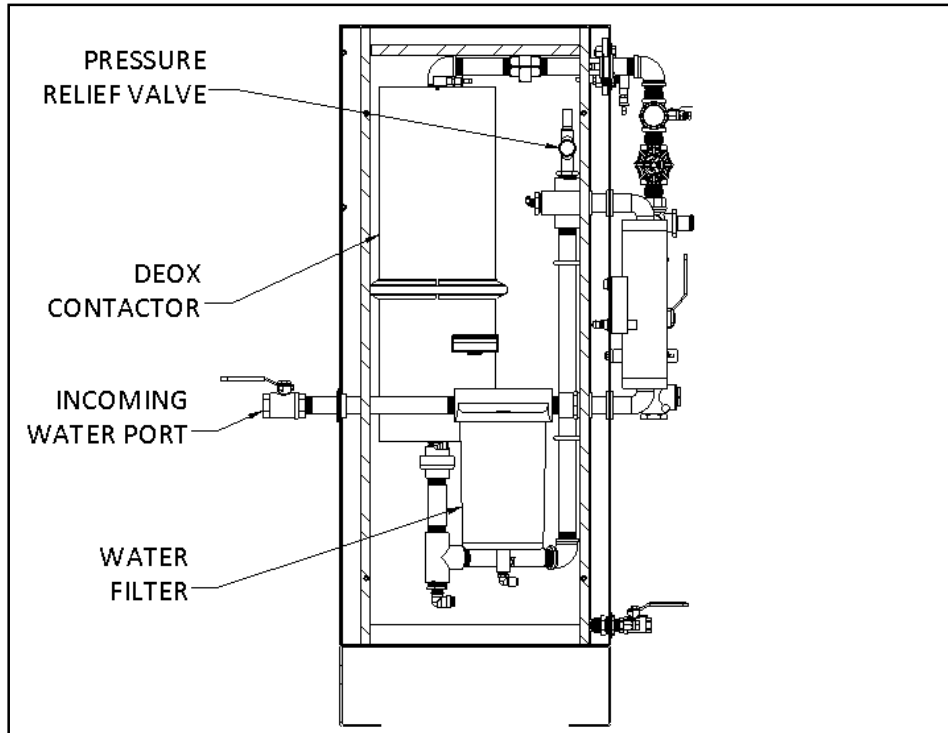

Figure 1: Key Features (Front View)

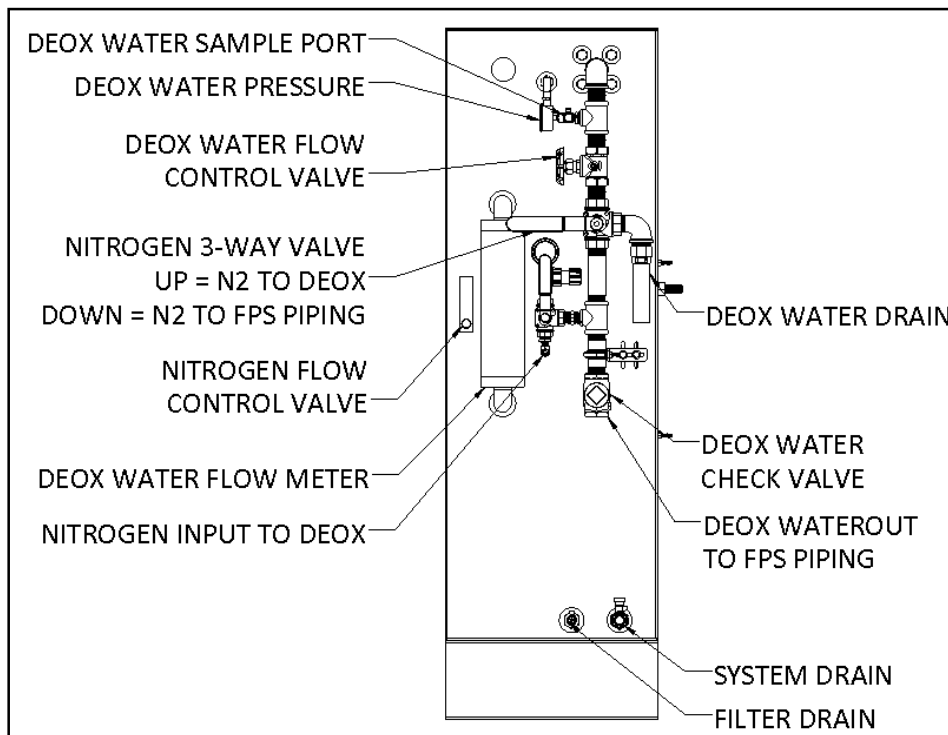

Figure 2: Key Features (Right Side View)

### 3.2 SPECIFICATIONS

*Table 1: DeOx™ FPS 1 Corrosion Inhibiting System Design Specifications*

DeOx™ FPS 1 Corrosion Inhibiting System – Specifications	
Nitrogen Purity Requirement	98.0+%
Installation	Floor standing with anchor bolt holes
Max System Water pressure	85 PSIG
Max Gas Supply pressure	30 PSIG
Input / Output Water Connections	1" NPT Female (both)
Input / Output Gas Connections	¼" or ½" NPT (both available on all units)
Electrical	None
Deox Water Output	~16 gpm @ < 0.3 PPM of O2
Operating Water Temperature	41° to 77°F
Noise Level (dbA)	< 75 dbA
Size	35" W x 18" D x 52" H
Weight	110 lbs

## 4 PRODUCT INSTALLATION

### 4.1 UNPACKING AND PREPARATION

The DeOx™ FPS 1 Corrosion Inhibiting System will arrive in a wooden crate which will need to be carefully unloaded off the truck. The use of a floor jack or fork truck is advisable. Open the side noted, “Open this Side”. Take any pictures upon arrival of the crate, for damages done during shipping. Identify and verify that all items listed on the packing list are present and undamaged. South-Tek Systems (STS) is not responsible for damages that have occurred during the shipping and handling of the DeOx™ FPS 1 Corrosion Inhibiting System. Any visual damages should be immediately documented and reported to the shipping company responsible. Then, contact STS at (888)526-6284 to assess the damages only after the shipping company has been notified.

#### **Until Installation and Operation:**

- The DeOx™ FPS 1 Corrosion Inhibiting System can be stored inside the wooden crate until installation. For extended storage of over one month, open and insert desiccant bags as needed to prevent moisture buildup.
- Store the DeOx™ FPS 1 Corrosion Inhibiting System in a dry and climate controlled (60-80°F) room.
- Always keep the DeOx™ FPS 1 Corrosion Inhibiting System in an upright position.
- Do not operate the system until this manual has been read completely and all connections are made as shown on the General Arrangement Drawings.
- Never place/stack objects on top of the DeOx™ FPS 1 Corrosion Inhibiting System.
- Keep safe from moving objects.

To remove the DeOx™ FPS 1 Corrosion Inhibiting System from the crate, unbolt the 4 bolts on the bottom of the crate which secure the system to the floor of the wooden crate. Carefully lift the unit out of the crate and set it on a flat surface floor. Carefully move the system to its installation location. The use of a floor jack is advisable to move it to the final location.

Carefully break down the crate and store in a safe location in the case that it may need to be sent back to the factory for service.

### 4.2 ELECTRICAL REQUIREMENTS

The DeOx™ FPS 1 Corrosion Inhibiting System requires no electrical connections. But being that it is a wet system, make sure electrical equipment around the system is properly protected from accidental exposure to the water in the system.

### 4.3 INSTALLATION

#### **Suitable Location Requirements:**

- Dimensions: 35" W x 18" D x 52" H (Recommended to leave at least 36" on left, right, and front side for ease of connection and maintenance)
- Level surface near the FPS Valve (main water supply valve)
- Keep away from moving objects that could interfere with the system
- Ambient temperature between 40° - 104°F
- Ensure there is adequate access to all the valves, K Cylinder (provide enough room for periodic cylinder change outs), and/or liquid nitrogen dewar for purging
- Conveniently, locate near drain

#### **Anchoring:**

The DeOx™ FPS 1 Corrosion Inhibiting System needs to be installed on a level surface capable of supporting the system's weight, associated piping, and nitrogen sources. There are (4) anchor bolt holes on the support legs that can be used to secure the unit to the floor. It is recommended to anchor the system to the level surface. Always follow any site/local codes regarding the safety and security of the equipment. It is recommended to leave 36" on all sides to allow for piping connections and serviceability.

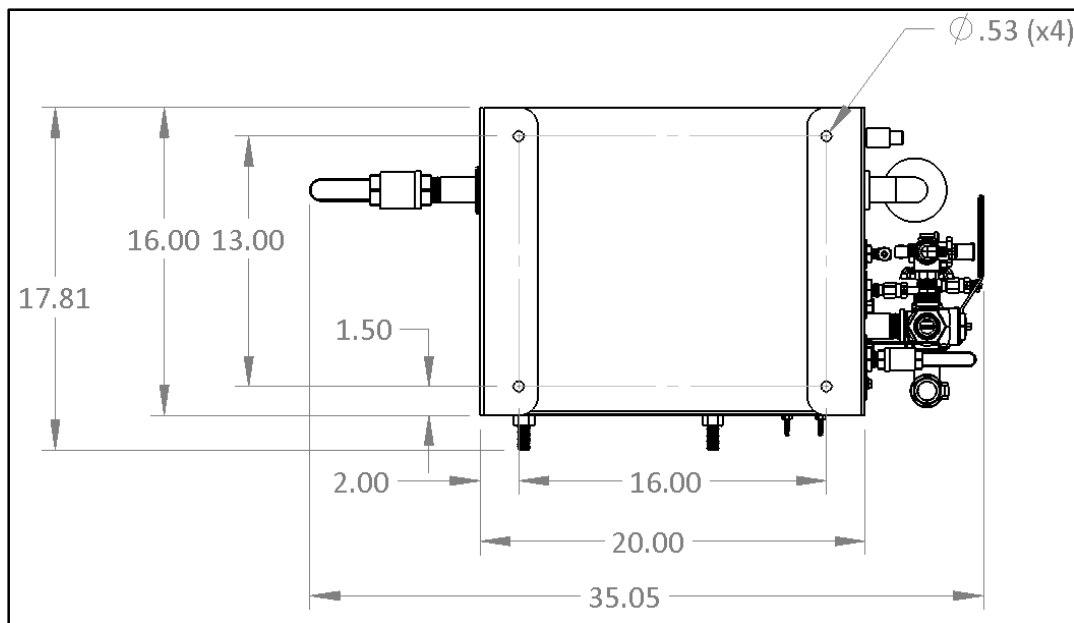

*Figure 3: System Base and Anchoring Dimensions*

**Recommended Piping Diagram:**

It is recommended to install the DeOx™ FPS 1 Corrosion Inhibiting System so that the system can be isolated in the case of an actual or accidental FPS system trip or for scheduled maintenance. If the Fire Sprinkler System requires a jockey pump to raise the pressure above 85 PSIG, it is recommend to plumb in isolation/bypass valves around the jockey pump. This is due to the fact that the DeOx system can not handle more than 85 PSIG. The jockey pump is only there for finalizing the system pressure.

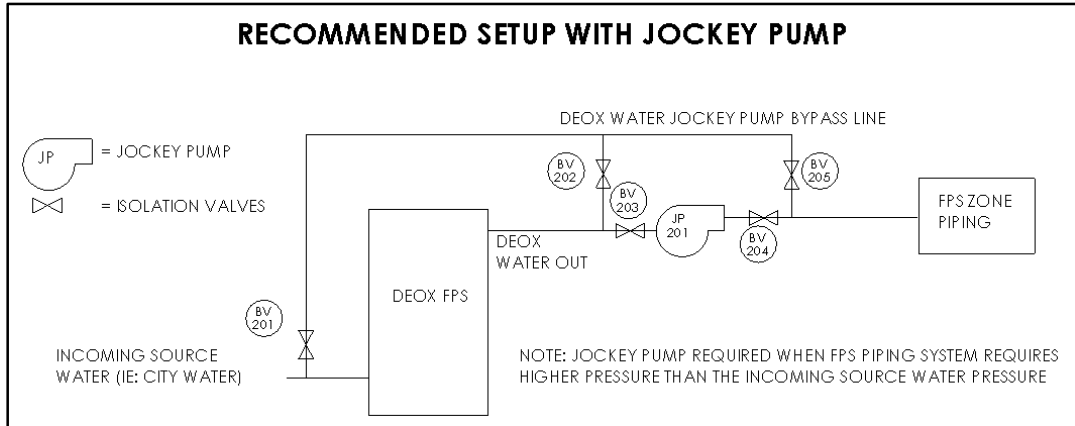

**Figure 4: Recommended Setup with Jockey Pump**

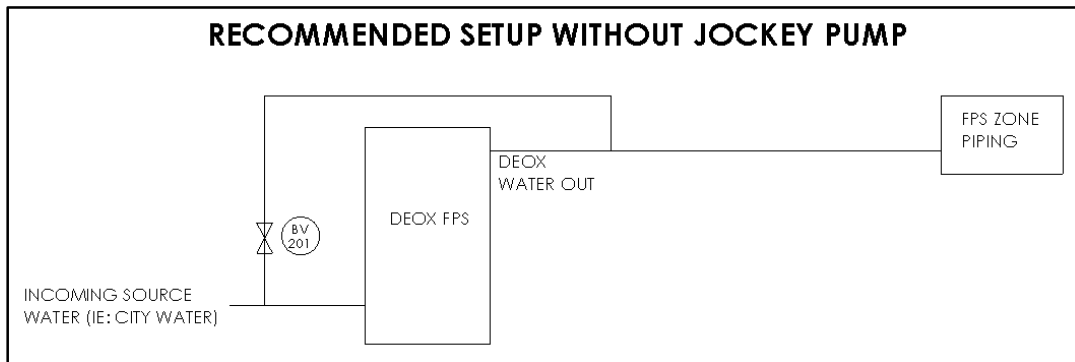

**Figure 5: Recommend Setup without Jockey Pump**

**Piping Connections to the Deox™ System:**

The system will need a water inlet, water outlet, nitrogen inlet, and three drain connections all piped prior to usage. See Figure 6 below for connection location and sizes. Make sure the drains are piped to a suitable wet drain that can handle up to 20 gallons per minute.

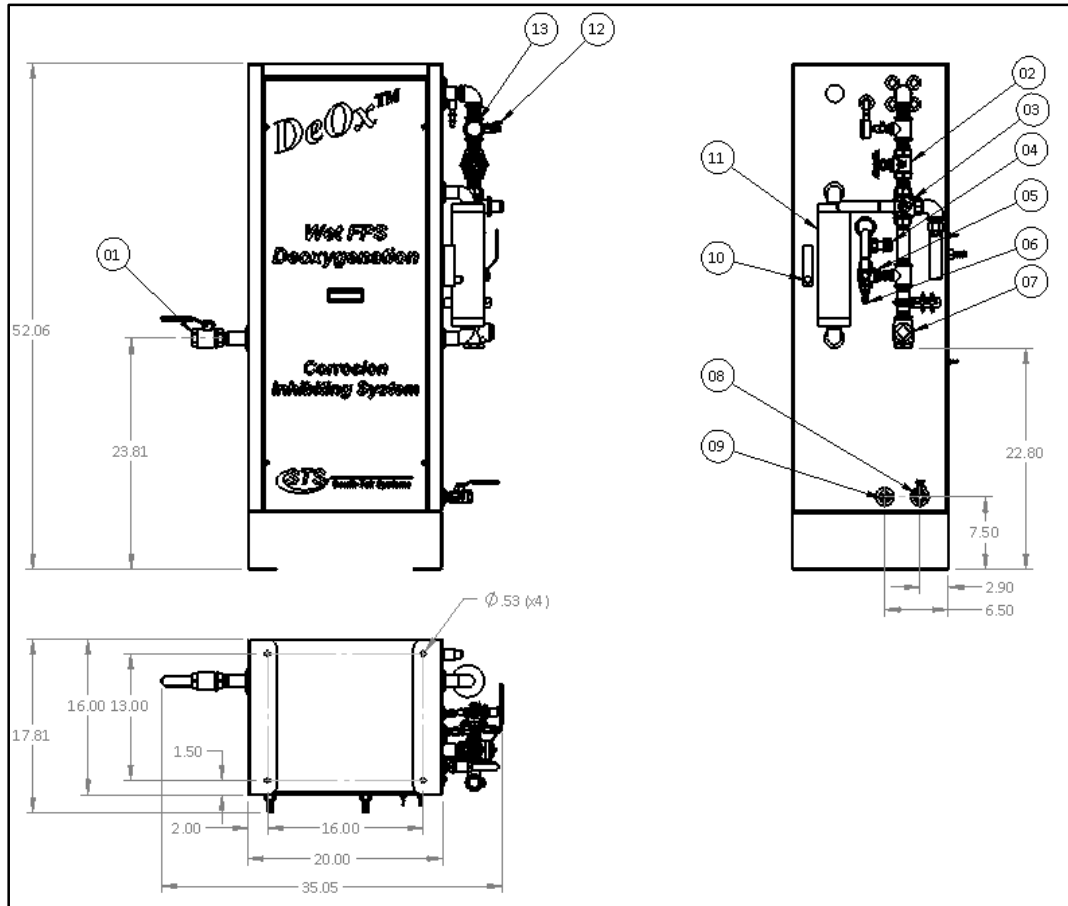

ITEM #	DESCRIPTION	SERVICE
01	1" NPT BALL VALVE	WATER IN
02	1" NPT GATE VALVE	DEOX WATER CONTROL VALVE
03	1" NPT 3-WAY BALL VALVE	HANDLE HORIZONTAL = DEOX TO DRAIN HANDLE VERTICAL = DEOX TO FPS
04	PRESSURE REGULATOR	N2 PRESSURE REGULATION TO DEOX
05	1/2" NPT 3-WAY BALL VALVE	HANDLE HORIZONTAL = N2 TO FPS HANDLE VERTICAL = N2 TO DEOX
06	1/4" 37° JIC FLARE MALE	N2 CONNECTION PORT TO DEOX
07	1" NPT CHECK VALVE	DEOX CONNECTION PORT TO FPS
08	1/2" NPT BALL VALVE	DEOX SYSTEM WATER DRAIN
09	1/4" NPT BALL VALVE	FILTER WATER DRAIN
10	1/4" N2 FLOW METER	N2 FLOW METERING TO DEOX
11	1" WATER FLOW METER	WATER FLOW INTO DEOX INDICATOR
12	1/4" BALL VALVE	DEOX WATER ANALYZER SAMPLE PORT
13	PRESSURE GAUGE	DEOX WATER OUT PRESSURE INDICATOR

Figure 6: System Connection Ports and Securing Nitrogen High Pressure K Cylinders

#### 4.4 NITROGEN SUPPLY TO THE SYSTEM

It is recommended to use a Nitrogen Dewar system (that will deliver at least 50 psig) to pre-fill the FPS piping system with >99.5% nitrogen (see Figure 6, Item 6 for connection information). Make sure a regulator is installed on the nitrogen supply vessel and set it to 30 PSIG, prior to turning on the nitrogen valve to the DeOx™ system.

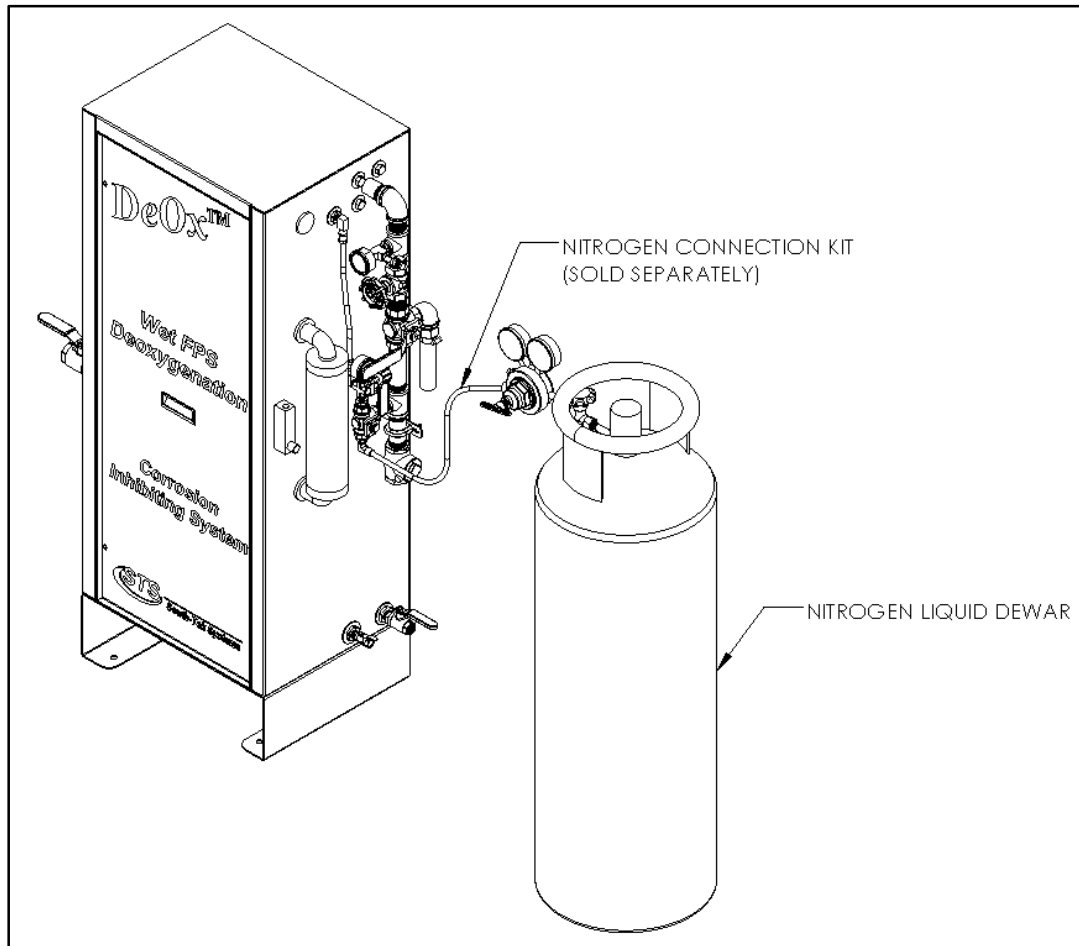

Figure 7: Nitrogen Connection to DeOx™



## **5 SYSTEM OPERATIONS**

The system is setup for a three step process:

1. Purging FPS Piping with >99.5% N<sub>2</sub> gas; achieve 98%+ N<sub>2</sub> in wet FPS
2. Filling the Fire Protection Zone with Deox water
3. Drying the Deox System

Complete process 1 and 2 for all zones prior completing step 3, unless there is a period where the DeOx™ will not be operated for a period longer than 4 hours (ie – when doing the process over multiple days, dry it out at the end of the day prior to leaving). Once all zones are full with the Deox water, proceed to the last process of drying the Deox system. Failure to complete process 3 will greatly shorten the life and performance of the system.

## 5.1 PROCESS 1: PURGING THE FPS PIPING TO >98% N<sub>2</sub>

This first process is required to prep the existing FPS piping system for the introduction of the DeOx water. This will help ensure low O<sub>2</sub> concentration remains within the trapped gas pockets during the water filling process. It also allows the water to maintain a low O<sub>2</sub> concentration by reducing the effects of Henry's law.

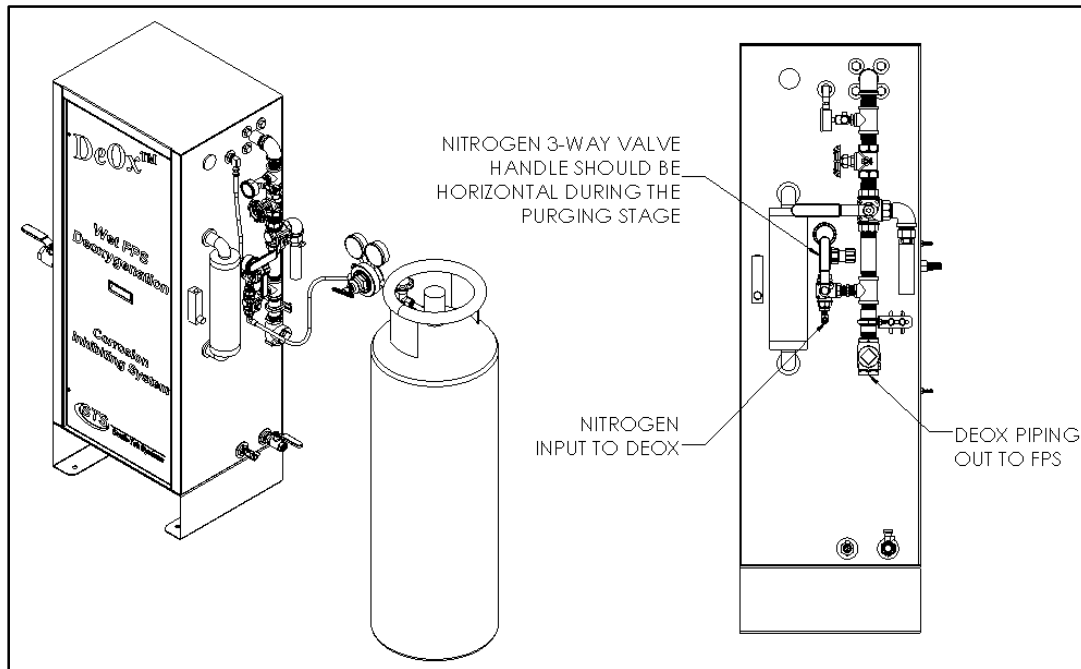

**Figure 8: Operation Procedure 1**

Perform the following steps for this first process (See Figure 8) – Note: This process should be performed by or in cooperation with a sprinkler system professional. Each system should be in “Test Mode” and capable of handling full system pressure.

- (1) Valve off Water Inlet Supply Valve.
- (2) Valve off High Pressure Cylinder.
- (3) Drain water from FPS zone. Once zone is completely drained, close off the system's drain valve and any FPS Air Vent Valves, if any are installed.
- (4) Set Handle of DeOx Nitrogen 3-Way Valve to the “horizontal” position.
- (5) Regulate N<sub>2</sub> incoming gas source to 20 PSIG and start filling N<sub>2</sub> to the FPS. Be careful not to flow in N<sub>2</sub> so fast that it freezes the line. Consult with the N<sub>2</sub> supplier for recommended max flow rate of their regulator and vessel.
- (6) Once FPS is at 20 psig (can be viewed at any gauge on the FPS piping system), shut off the N<sub>2</sub> at the supply source (ie Dewar output). Drain pressure off the system at the Inspector's Test Port (ITP). Close off ITP immediately when pressure falls between 2 and 5 PSIG.
- (7) Repeat Step 5 and 6 again.
- (8) Check N<sub>2</sub> gas at ITP with an N<sub>2</sub> analyzer and make sure that it is greater than or equal to 98% N<sub>2</sub>. If it is not, repeat step 7 again until the zone reaches greater than or equal to 98% N<sub>2</sub>.
- (9) End of Process 1.

## 5.2 PROCESS 2: FILLING FIRE PROTECTION ZONE WITH DEOX WATER

This second process introduces Deox water less than 0.3 PPM of O<sub>2</sub> into the FPS piping. Performing this properly ensures that the wet system will have very low O<sub>2</sub> concentration within the pipe and also minimize or eliminate trapped air pockets.

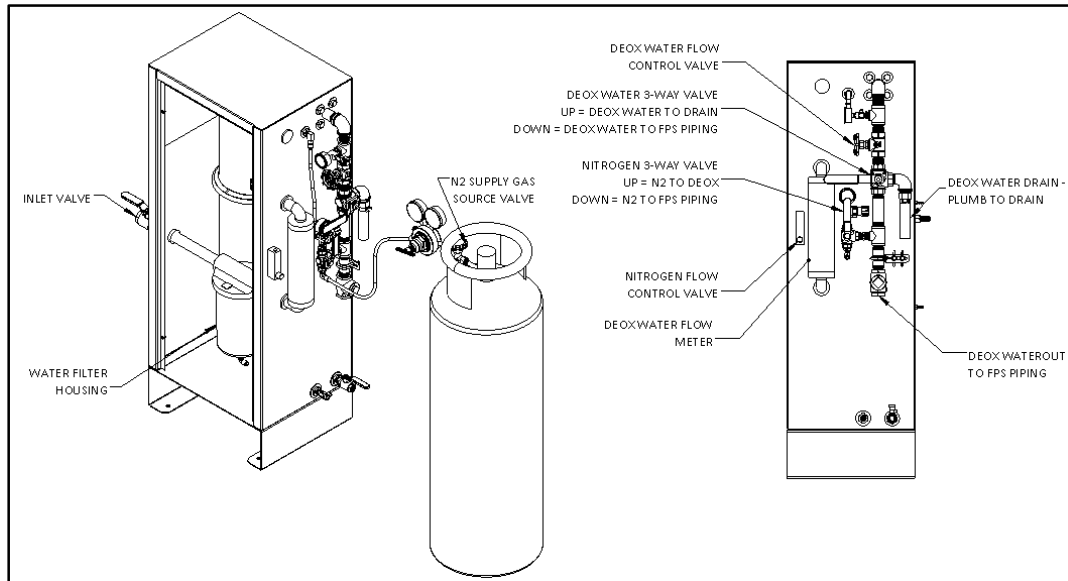

**Figure 9: Operation Procedure 2**

Perform the following steps for this second process:

- (1) Close Inspector's Test Port (ITP) and Air Vent Valves (if installed).
- (2) Close Water Inlet Valve. Max water pressure to system is 85 psig (between 41-77°F). Add pressure regulator prior to water inlet valve if supply water is > 85 PSIG.
- (3) Install clean filter bag (STS Part #004-342-A) in water filter.
- (4) Valve off N<sub>2</sub> supply gas at the source (ie. N<sub>2</sub> Dewar or N<sub>2</sub> Bottles).
- (5) Make sure Deox Water Drain is piped to a drain.
- (6) Set N<sub>2</sub> 3-way valve to the vertical position.
- (7) Set Deox Water 3-Way Valve to the horizontal position.
- (8) Open Water Inlet Valve slowly.
- (9) Set water flow rate to 16 gpm by adjusting water flow control valve.
- (10) Open N<sub>2</sub> supply gas and set N<sub>2</sub> Pressure Regulator to at least 5 psig less than incoming water pressure with the max pressure of N<sub>2</sub> being 30 PSIG.
- (11) Adjust the N<sub>2</sub> flow control valve to 2 scfm.
- (12) Open Deox Water 3-Way Valve to vertical position allowing flow to FPS Zone (also, open any isolation valves between DeOx System and FPS Zone).
- (13) Open Air Vent Valves (if installed) after water starts flowing into FPS zone.
- (14) Allow FPS zone pressure to reach 30 PSIG. Then, slightly open ITP allowing gas to escape but not so much that system drops below 10 PSIG.

- (15) Once a steady stream of water starts flowing from ITP valve, shut it off completely and allow DeOx system to continue fully pressurizing the FPS zone. Switch the DeOx water over to jockey pump or test pump, if needed, to increase pressure in the FPS zone.
- (16) Close off Water Inlet Valve. Turn DeOx Flow Valve back to the horizontal position, and shut off N<sub>2</sub> supply gas.
- (17) Proceed back to Procedure 1 if filling another zone, or go to procedure 3 if that is the last zone.
- (18) End of Process 2.

### 5.3 PROCESS 3: DRYING THE DEOX™ CONTACTOR

Once all the zones are filled, the contactor needs to be dried out for peak performance on the next use. This final step is very important in prolonging the life of the system and allowing the system to maintain design performance.

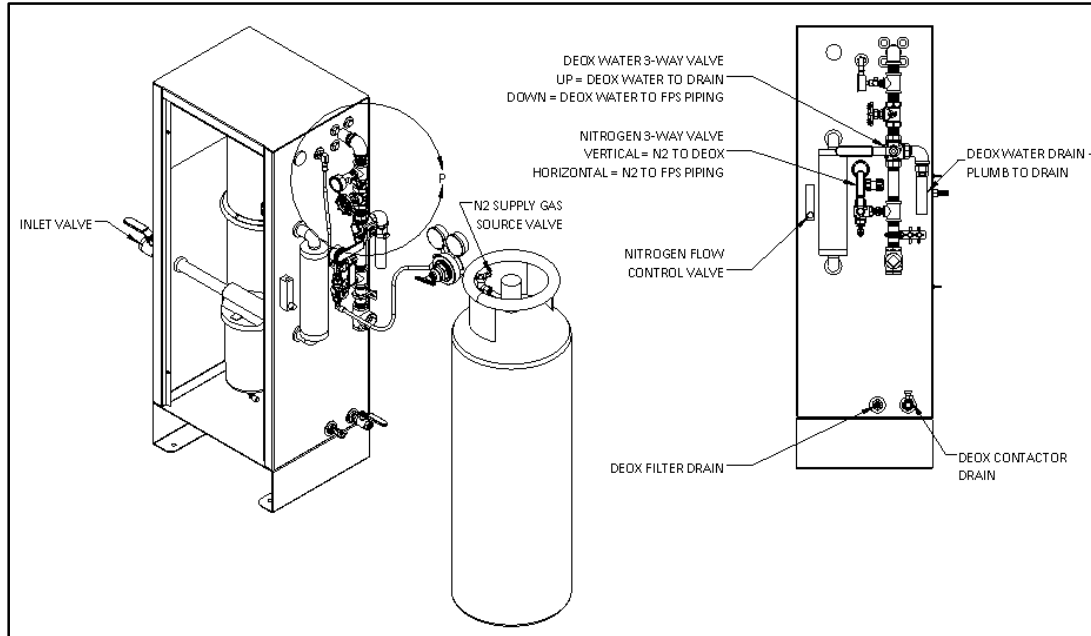

**Figure 10: Operation Instruction: Procedure 3**

Perform the following steps for the third process:

- (1) Valve off N<sub>2</sub> supply gas at the N<sub>2</sub> gas source (ie N<sub>2</sub> dewar, bottles, etc).
- (2) Valve off Water Inlet Valve.
- (3) Set N<sub>2</sub> 3-Way Valve to the vertical position.
- (4) Set Deox 3-Way Valve to the horizontal position.
- (5) Make sure Filter Drain Port and DeOx Contactor Drain Port are plumbed to a drain. Open valves slowly and allow the water to completely drain.
- (6) Once the water is completely drained, open the N<sub>2</sub> supply gas and regulate the pressure down to 1-2 PSIG and flow at < 0.5 scfm. Allow the nitrogen to purge through the system for 24 hours.

## 6 SYSTEM USAGE

### 6.1 INSTRUCTIONS

The DeOx™ FPS 1 Corrosion Inhibiting System is intended to prefill the system with nitrogen and supply deoxygenated water to the piping system. Follow the installation instructions and only use in an approved environment. Make sure that proper regulators, connection fittings, and piping are used. Please consult with your local provider for questions not answered in this manual.

The system is designed for continuous flow, but when flow is not needed, the system must be dried out properly.

### 6.2 DEOX™ O<sub>2</sub> METER

The system is equipped with a water sample port to verify the O<sub>2</sub> content in the water. This equipment can be purchased or rented from South-Tek Systems. Keep the ¼" NPT Ball Valve closed until the O<sub>2</sub> water sampling kit is installed. Please contact South-Tek Systems for further details on conducting an O<sub>2</sub> water sample.

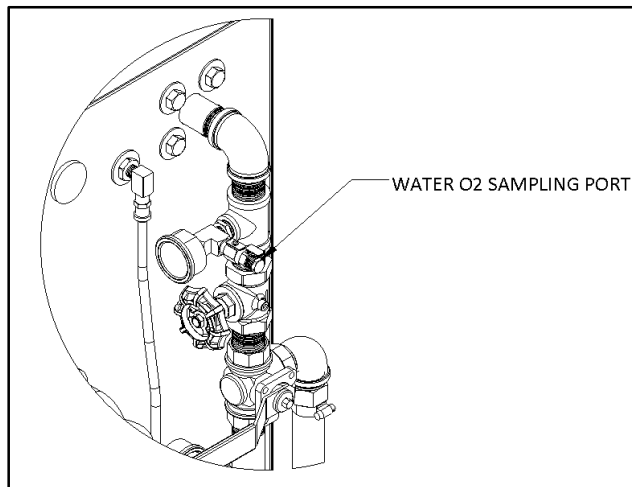
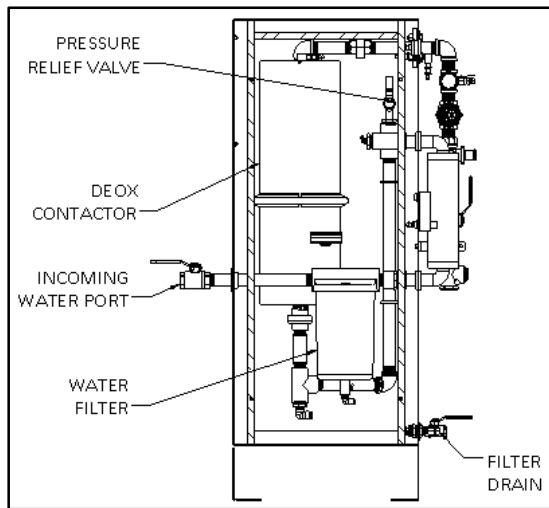

*Figure 11: Deox O<sub>2</sub> Water Sampling Port*

## 7 SYSTEM MAINTENANCE

### 7.1 WATER FILTER BAG REPLACEMENT

The system is equipped with a 5 micron bag filter (STS Part # 004-342-A) to capture large particles before it enters into the contactor. It is recommended that a new bag filter be install at the start of each use. To change out the bag filter, first make sure the incoming water is shut off and all pressure is off the system. Open the drain on the filter to drain any water present. Then, simply twist off the main housing (filter removal tool is provided for ease of removal), and remove the old bag and replace it with the new bag filter. Twist the main housing back on and the filter bag change out is complete.



*Figure 12: Water Filter*

### 7.2 DRYING DEOX CONTACTOR

As mentioned previously, drying the system is a very important process in prolonging the life of the system and maintaining design performance. See section 5.3 Process 3: Drying The DeOx™ Contactor for instructions on how to dry out the system.

## 8 KEY CONTACTS

Contact your local provider/installer for any questions regarding the installation and operation of the system. They will be best suited to answer your questions and your quickest solution to any issues you may have. For questions that they cannot answer, please contact South-Tek System's Service Department.

South-Tek Systems

2940 Orville Wright Way, Wilmington, NC 28409

Phone: 888-526-6284 | E-mail: [info@southteksystems.com](mailto:info@southteksystems.com)

## **9 FAQs**

### **1. System not able to flow to design flowrate:**

If the DeOx™ FPS 1 Corrosion Inhibiting System is not able to produce the design flowrate check the following:

- a. Make sure the incoming water supply valve and all water valves prior to the system are fully opened.
- b. Check the filter and see if the filter bag is clogged up. Water cleanliness varies from site to site. Change the filter bag as needed.
- c. Make sure the supply N2 gas is regulated correctly. It should always be at least 5 psig less than the incoming water and also no more than the system's design gas pressure (30 PSIG max).

### **2. Pressurizing the FPS piping zone to pressure:**

If the FPS piping system equals the incoming water supply pressure and the water pressure still needs to be increased, switch the valves to run the DeOx water through the jockey pump or test pump. Make sure the jockey pump is set up correctly to deliver DeOx water to wet FPS system pressure.



## APPENDIX A: WARRANTY

The DeOx™ FPS 1 Corrosion Inhibiting System is warrantied against any defects in workmanship and materials for 12 months from the date of shipment from South-Tek Systems. The purchaser has the liability to ensure that the system is fully inspected upon delivery and shall contact the appropriate shipping company to make any claims on damaged goods due to transit within that shipping company's policies. If the system is received with defects that are not due to shipping, a written claim shall be submitted to South-Tek Systems within 1 week of receiving the shipment. South-Tek Systems can deny all other claims at their discretion.

All warranty work shall be done at a South-Tek Systems facility or at a DeOx™ FPS 1 Corrosion Inhibiting System Authorized Service Center. Only factory trained and authorized personnel are covered under warranty. Any part that is returned / repaired / replaced under warranty may be remanufactured or changed to a different specification at the factory's option. Any work performed by an unauthorized person/company or usage of non-factory parts, may void all warranties to the product.

Any item not manufactured by South-Tek may carry its own warranty from its manufacturer and will be warrantied by that manufacturer. All parts that need to be returned should be announced. Any item(s) that is returned to South-Tek Systems without an RMA number (return authorization number) may be denied and returned to the sender. Contact the factory for RMA #'s, prior to return shipment.

South-Tek Systems is not liable for damages caused by normal wear and tear, water, fire, erosion, corrosion, explosion, misuse, oil/gas vapors, quality of supply water, or improper maintenance. South-Tek Systems is not liable for any losses (including N<sub>2</sub>), damages, or cost of delays, including incidental or consequential damages. There are no warranties or guarantees, expressed or implied, including the warranties of merchantability or fitness for a particular purpose or use, other than those warranties expressed herein.

For Claims, contact South-Tek Systems LLC at:

tel (888- 526-6284 fax (919) 847-0255

Email: [support@southteksystems.com](mailto:support@southteksystems.com)

Or write to:

South-Tek Systems, Warranty Claims,  
2940 Orville Wright Way,  
Wilmington, NC 28405

## **APPENDIX B: General Arrangement Drawings**